

Operating manual

Band-saw machine for plastic pipes

Type BSM 631 / BSM 800 / BSM 1000



Status April 2016

© Eugen Riexinger GmbH & Co. KG

Table of contents

1. Important basic information	5
1.1 Operator evaluation.....	5
1.2 Legal notice.....	5
1.3 Safety symbols.....	5
1.4 Used notation styles.....	6
1.5 Used abbreviations.....	6
1.6 Location of objects in the room.....	7
1.7 Labelling on the machine.....	8
2. Basic safety instructions	9
2.1 Behaviour in case of emergency.....	9
2.2 Follow the operating manual.....	9
2.3 Usage according to regulations.....	9
2.4 Improper usage.....	10
2.5 Personnel requirements.....	10
2.6 Informal safety measures.....	12
2.7 Properly functioning of protective devices.....	12
2.8 Organizational measures.....	12
2.9 Other hazards.....	12
2.9.1 Fire hazard.....	13
2.9.2 Electrical hazards.....	13
2.9.3 Laser radiation (optional).....	13
2.9.4 Mechanical hazards.....	14
2.9.5 Heat hazards.....	14
2.9.6 Environmental hazards.....	14
3. Technical data	15
3.1 General information.....	15
3.2 Delivery contents.....	16
3.3 Dimensions and weight.....	16
3.4 Equipment.....	16
3.5 Workpieces.....	17
3.6 Electrical connection.....	17
3.7 Pneumatic connection (optional).....	18
3.8 Suction of saw shavings.....	18
3.9 Emissions.....	18
4. Setup and function	21

4.1 Overview.....	21
4.2 Functionality.....	22
4.3 Safety concept.....	22
4.3.1 Emergency-off circuit.....	22
4.3.2 Safety button.....	23
4.3.3 Further safety equipment.....	23
5. Delivery, in-company transport and storage.....	25
5.1 Delivery.....	25
5.2 Environmental conditions for storage and transport.....	25
5.3 In-company transport.....	25
6. Setup and activation.....	27
6.1 Setup location.....	27
6.1.1 Floor conditions.....	27
6.1.2 Lighting.....	27
6.2 Environmental operating conditions.....	27
6.3 Setup plan.....	28
6.4 Setting up the machine.....	29
6.5 Connect to electrical power supply.....	30
6.6 Establish pneumatic connection (optional).....	30
6.7 Connect to suctioning (optional).....	31
6.8 Initial operation.....	31
7. Operation.....	33
7.1 Before start-up.....	33
7.2 Protective equipment.....	33
7.3 Turning the BSM 631 / BSM 800 / BSM 1000 on and off.....	33
7.4 Control panel.....	34
7.5 Foot pedal (optional).....	35
7.6 Setting the saw feed rate.....	35
7.7 Setting the sawing angle.....	37
7.8 Loading the machine.....	38
7.9 Space between saw-band guide and workpiece.....	42
7.10 Sawing.....	43
8. Finding and repairing malfunctions.....	45
8.1 Repairing mechanical malfunctions.....	45
8.2 Repair electrical malfunctions.....	46
8.3 Check saw-band motor.....	47
8.4 Setting lower limit switch.....	48

8.5 Set optical cut indicator (optional).....	49
8.6 Guarantee.....	50
8.7 Error report.....	51
9. Maintenance.....	53
9.1 Cleaning the machine.....	54
9.2 Tensioning the saw band.....	55
9.3 Removing the saw band.....	58
9.4 Inserting the saw band.....	60
9.5 Greasing.....	62
9.6 Check safety equipment.....	64
9.7 BSM 631 / BSM 800 / BSM 1000 maintenance.....	66
10. Dismantling and disposal.....	69
10.1 Deactivation.....	69
10.2 Final shutdown.....	69
10.3 Disposal.....	69
11. Annex.....	71
11.1 Contact form.....	71
11.2 EC Conformity Declaration.....	73
11.3 Dimension sheets.....	75
11.3.1 Dimension sheet BSM 631.....	75
11.3.2 Dimension sheet BSM 800.....	77
11.3.3 Dimension sheet BSM 1000.....	79
11.4 Circuit diagram.....	81
11.5 Pneumatic diagram (optional).....	82
12. Other informations.....	83

1. Important basic information

1.1 Operator evaluation

Dear operator,

Our operating instructions are updated on a regular basis. Your suggestions for improvement help us create an increasingly user-friendly operating manual. Please use the contact form for your suggestions (see Chap. 11 on p. 71).

1.2 Legal notice

Without explicit, written authorisation of the company Eugen Riexinger GmbH & Co. KG the operating manual may not be electronically or mechanically copied, distributed, changed, forwarded, translated into another language nor used in any other way.

The company Eugen Riexinger GmbH & Co. KG is not liable for damages resulting from non- or partial compliance with the operating manual.

1.3 Safety symbols

This operating manual uses the following designations and symbols for hazards:



Danger!

This symbol refers to an *immediate danger to the life and health* of a person.

Disregarding such notices results in severe harm to a person and may even cause fatal injuries.



Warning!

This symbol refers to a *potentially immediate danger to the life and health* of a person.

Disregarding such notices *may* result in severe harm to a person and may even cause fatal injuries.



Caution!

This symbol refers to a *potentially harmful situation*.

Disregarding such notices may result in minor harm to a person or material damage.

**Attention!**

This symbol gives important information for properly handling the machine. Disregarding such notices may result in malfunctions or material damage *of the machine or cause damage to the environment.*

**Information**

This symbol provides *instructions* and particularly useful information. Such information helps you use all functions of your machine optimally.

1.4 Used notation styles

This operating manual uses the following notation styles:

- Words or sentences with emphasised meaning are written in *italics*.
- **Control elements** on the control panel are written in blue font.
- The instructions, which the operator follows to perform specific functions, always begin with a number or a letter. Activities or notifications, which the machine uses as a response to executed instructions, are marked with a preceding full stop, e.g.:

1. Instruction
 - a. Instruction
 - Response or notification from machine

1.5 Used abbreviations

IndSafReg	Industry Safety Regulations (German implementation of Guideline 2009/104/EG)
DGUV	German Social Accident Insurance (electrical facilities and manufacturing equipment)
Roule 3	of the Professional Association for Health and Social Welfare
BSM	Band saw machine
GFP	Glass fibre-reinforced plastic
PE	Polyethylene (thermo-plastic synthetics)
PP	Polypropylene (partial crystalline thermo-plastic synthetics)
PVDF	Polyvinylidene fluoride (opaque, partial crystalline thermo-plastic fluorine synthetics)
APR	Accident Prevention Regulations

1.6 Location of objects in the room

The spatial information about locations of objects in the room in relation to the BSM 631 / BSM 800 / BSM 1000 always refer to the image below.







Abb. ähnlich

1.7 Labelling on the machine

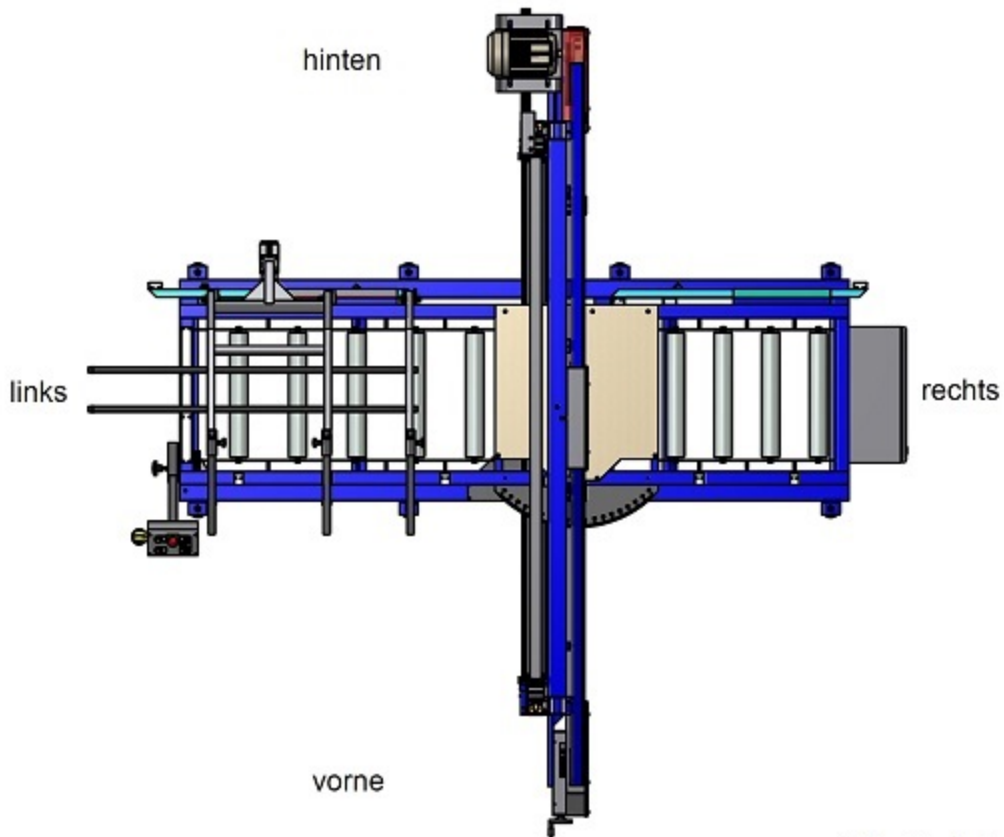
Symbol	Attachment location	Meaning
	Saw bow (near the saw band)	Warning of severance- and cut injury caused by saw band
	Saw bow (near the optical cut indicator, optional)	Warning of laser beams
	Switchboard cabinet Control panel Electrical components	Warning of dangerous electrical voltage when opening the door of the switchboard cabinet or the control panel casing or touching electrical components
	Pneumatic pipe tension (optional)	Warning of crushing between the fixed and moving machine parts
TYPE LABEL	Switchboard cabinet	Type label and CE marking of the BSM 631 / BSM 800 / BSM 1000

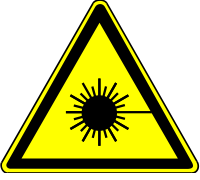
2. Basic safety instructions

This chapter contains basic safety instructions for operating the BSM 631 / BSM 800 / BSM 1000 safely.

2.1 Behaviour in case of emergency



Warning!

Running saw band may injure the operator!

The saw band has a delayed stop-time of 4 seconds.

After pressing the [emergency-off button](#) or deactivating the [main switch](#), wait until the saw band has come to a complete stop before entering the saw-band area.

How to shutdown the machine in an emergency:

- 1) Press the [emergency-off button](#) on the machine's control panel (see Chap. 7.4 on p. 34).
- 2) Turn the machine off with the [main switch](#) at the switchboard cabinet (see Chap. 7.3 on p. 33).
- 3) Call for an authorised person who can discover the reason for the emergency and fix the problem.

2.2 Follow the operating manual

- Carefully read this operating manual before using the machine for the first time.
- Familiarize yourself well with all safety instructions contained therein and observe these at all times when working with the machine.
- Always keep the operating instructions on hand near the machine.
- If the machine is transported to a new location, give these instructions to the new operator.

2.3 Usage according to regulations

The BSM 631 / BSM 800 / BSM 1000 is exclusively designed for sawing pipes with the properties and dimensions outlined in this operating manual (see Chap. 3.5 on p. 17). Proper usage also includes:

- Observing all guidelines from the operating manual and
- Adhering to maintenance intervals

The BSM 631 / BSM 800 / BSM 1000 is exclusively intended for usage in industry, craft and trade. It is not intended for private usage.

2.4 Improper usage

The BSM 631 / BSM 800 / BSM 1000 may not be -

- operated by more than one person (exceptions are described in the respective context);
- operated with deactivated safety button when the operator has not implemented the appropriate protective measures (e.g. safety fence) to keep the hazard area clear of people during operation;
- operated with deactivated safety button without operator supervision (with automatic saw feed);
- operated when not all protective equipment are available or fully functional:
- operated when malfunction and defects have not been repaired:
- modified or changed;
- operated in an explosive atmosphere;
- operated in a dusty environment without appropriate ventilation;
- be operated outdoors but only in inside rooms.

Furthermore, it is also not permissible to -

- modify the performance or the rotational speed of the motors;
- bypass the safety button, the end switch, the control elements or other control components;
- saw materials that are not intended for the machine BSM 631 / BSM 800 / BSM 1000 as e.g. wood or metal;
- work on the machine without the personal protective gear prescribed in this operating manual.
- work on the machine with influence of alcohol, drugs and/or medicines.

2.5 Personnel requirements

The BSM 631 / BSM 800 / BSM 1000 may only be operated by trained personnel whom the operator has authorised.

Personnel who are still learning how to work with the machine or apprentices may only operate it under the constant supervision of an instructed person.

***Instructed person***

A person who is at least 18 years old and has been sufficiently instructed or supervised by a trained employee and is therefore able to recognize risks and avoid hazards.

***Authorised person***

- Person who has a reliable understanding of safety-related technological issues due to professional expertise acquired through training, experience and recent professional activities
- The authorised person must have knowledge of state-of-the-art technology for the tasks to be executed and recognise hazards; he must also maintain this state of expertise.

***Warning!******Electrocution hazard!***

Only professional electricians may perform work on the machine's electrical equipment according to the electro-technological regulations.

The following table shows the personnel that is allowed to work with the machine in a particular life-phase the qualifications that this person must possess.

Life-phase	Instructed person	Authorised person
Transport	–	+
Installation	–	+
Activation	–	+
Operation	+	+
Malfunction search	+	+
Maintenance	+	+
Storage	–	+
Deactivation	–	+
Dismantling	–	+
Disposal	–	+

2.6 Informal safety measures

- Always keep the operating instructions on hand near the machine.
- In addition to this operating manual, adhere to general and local accident prevention- and environmental protection regulations.
- Ensure that all safety instructions and danger notices attached to the machine (see Chap. 1.7 on p. 8) are legible and replace them if necessary.

2.7 Properly functioning of protective devices

All protective devices must be installed and function properly before starting up the machine (see Chap. 7.2 on p. 33).

Protective devices may be removed for repair work -

- after the machine is idle and
- and after the machine has been secured against re-activation (e.g. locking the main switch).

2.8 Organizational measures

The proprietor of the BSM 631 / BSM 800 / BSM 1000 is obligated to provide the required personal protective equipment. The personal protective equipment includes:

- Work clothing
- Safety glasses
- Protective gloves
- Hearing protection
- Lifting device for loading and unloading of pipes to be sawed
- Climbing aid for maintenance

Do not wear loose clothing, bracelets, necklaces or other objects that could get caught in the moving parts of the machine.

Furthermore, the proprietor must ensure the regular examination of all existing safety equipment (see Chap. 9.6 on p. 64).

2.9 Other hazards

In the following you will find the overridingly valid safety instructions that are relevant for several of the BSM 631 / BSM 800 / BSM 1000 life phases. Specific safety instructions are listed in the relevant sections of this operating manual.

2.9.1 Fire hazard



Warning!

Fire hazard due to plastic waste

- Keep ignition sources away from the work area.
- Do not smoke in the work area.
- Ensure that no open fire ignites in the work area.

Fire protection

- Never use water to extinguish a fire source; always use sand, carbon dioxide or powder.
- It is imperative to turn off the machine at the main switch or disconnect the power supply before extinguishing a fire source.

2.9.2 Electrical hazards



Warning!

Directly or indirectly touching live parts may result in electrocution.

- Turn off the main switch before opening the door of the switchboard cabinet.
- Pull the power plug or deactivate the power supply before working on electrical components.
- Electrical components are not protected against spray water. The proprietor must implement appropriate protective measures.

2.9.3 Laser radiation (optional)



Information!

Important informations about the laser!

- The used laser is a laser class 1 according to DIN EN 60825-1:2008-05. The accessible laser radiation is harmless.

2.9.4 Mechanical hazards



Danger!

Running saw band may cause serious severance injury!

Descending saw bow may pinch the operator!

- The machine may only be operated by one person.
- Before running the saw band or lowering the saw bow, the operator must ensure that the area behind the workpiece and the work area are clear.



Danger!

Climbing onto the machine poses a fall- and injury risk due to sharp machine parts!

It is not permissible to climb onto the machine when performing maintenance- or any other kind of work. Use suitable climbing aids (e.g. stepladders or multi-purpose ladders, but no leaning ladders).

2.9.5 Heat hazards



Attention!

After sawing the hot saw band may burn the operator!

Wear protective gloves during repair work or allow the saw band to cool down before touching it.

2.9.6 Environmental hazards



Attention!

Plastic waste and used saw bands contaminate the environment!

Dispose of all shavings, plastic waste and used saw bands according to locally applicable legal stipulations.

3. Technical data

3.1 General information

Machine construction

- Robust, torsion-resistant machine stand and saw frame made of steel
- Saw-band redirection with ball bearings
- Compensation for warmth-induced expansion of the saw band with band-tensioning device

Cut quality

- Precision guides for straight cuts
- Adjustable saw-band guide for straight cuts
- High saw-band speed for optimal cut quality
- Seamlessly adjustable feed rate of saw bow for various materials and wall thicknesses

Operation

- Tensioning of workpieces with clamping belts
 - *optional*: Pneumatically pipe clamping for fast and secure clamping of workpieces
- V-Support for pipes with small diameters (optional)
- Exact adjustment of saw angle possible with angle scale at front
- Mitre area of 45 degrees on both sides with swivel-mounted saw bow (optimal for manufacturing curved segments)
- Visual cutting indicator for quick positioning of workpiece (optional)
- Automatic cutting depth limit
- Automatic air blow system to clean saw band (optional)
- control panel

3.2 Delivery contents

The delivery contents of the BSM 631 / BSM 800 / BSM 1000 consist of:

- BSM 631
- 2 Saw bands for polyester pipes
- control paneel
- 6 Screw feet
- 2 tension belts
- 1 Operating Manual

3.3 Dimensions and weight

	BSM 631	BSM 800	BSM 1000
Length	2300 mm	2800 mm	3800 mm
Width at straight cut	2800 mm	3250 mm	3700 mm
Width at angle cut	2300 mm	2400 mm	2800 mm
Maximum Height (completely raised saw bow)	2800 mm	3250 mm	3700 mm
Weight ca.	450 kg	650 kg	980 kg

Transport dimensions

	BSM 631	BSM 800	BSM 1000
Length	2700 mm	2800 mm	3800 mm
Width	2300 mm	2400 mm	2800 mm
Height	2070 mm	2300 mm	2450 mm

3.4 Equipment

Saw band

	BSM 631	BSM 800	BSM 1000
Dimensions in mm	Art.-No. 300231 6280 x 25 x 0,9	Art.-No. 301288 7340 x 25 x 0,9 mm	Art.-No. 302256 8140 x 25 x 0,9
Tooth pitch(Tz)	4 bzw. 6 ZpZ (depending on wall thickness of workpiece)		

**Caution!**

Saw bands that jump off the spool may injure the operator or cause material damage.

Use original saw bands from the machine's manufacturer. Saw bands from other providers may jump off the spool and injure the operator or cause material damage to the machine or workpiece.

3.5 Workpieces

Type of material	PE, PP, PVDF plastics (other types of plastics after consultation with manufacturer)		
Profile	Pipe with circular cross-section (deviations from circular cross-section permissible up to ca. 50 mm)		
	BSM 631	BSM 800	BSM 1000
min. diameter in mm	200	200	315
max. diameter in mm	630	800	1000
min. length	The workpiece must be tensioned sure.		

**Attention!**

The BSM 631 / BSM 800 / BSM 1000 may only be used to saw glass fibre-reinforced plastics when the GFP-dust is ventilated with a ventilation system.

Dust is released into the air when sawing GFP, and this dust can very quickly shutdown mechanical components and electrical equipment of the BSM 631 / BSM 800 / BSM 1000. Therefore, a suitable ventilation system is absolutely necessary when sawing GFP.

3.6 Electrical connection

	BSM 631	BSM 800	BSM 1000
Operating voltage	400 V 3~/N/PE		
Frequency	50 Hz		
Power rating	5 kVA	5kVA	7,1kVA
Connection Type	CEE-plug-in, 32 A, 400 V		
Phase sequence	Field turning clockwise		

Saw band operation

	BSM 631	BSM 800	BSM 1000
Mechanical output with overload protection with electrical brake	2,5 kW	2,5 kW	4,0 kW

Saw bow motor

	BSM 631	BSM 800	BSM 1000
Mechanical output with overload protection Rotational speed control via frequency inverter	0,37 kW	0,37 kW	0,5 kW

3.7 Pneumatic connection (optional)

Minimum pressure	5 bar
Operating pressure	6 bar
Maximum pressure	8 bar
Connection	1/4" plug fitting

3.8 Suction of saw shavings

Shavings produced during cutting of plastic pipes can be removed by suction. For this machine must be connected to an suction system.

3.9 Emissions

Dust



Caution!

Sawing plastic materials releases fine dust into the air, which may harm the operator's health!

- Adhere to the respective legal regulations and determined workplace threshold values for dust.
- The proprietor is obligated to install a ventilation system and provide the operator with a respiratory mask if workplace threshold values are exceeded.

Noise emissions

emission sound pressure level at workstations L_{pA} (drive systems, ca.) 77,5 dB(A)
emission sound pressure level at workstations L_{pA} (sawing mode, ca.) 85,5 dB(A)
respective in 1 m radius



Attention!

Permanent high levels of noise at the workplace can cause irreversible damages to hearing!

- Therefore, the operator must wear hearing protection at the workplace during the sawing mode at an emission sound level from 80 dB (A).

EMC

The BSM 631 / BSM 800 / BSM 1000 complies with protection requirements in regard to interference immunity according to EN 61000-6-2:2005 (Interference immunity for industrial areas).

The BSM 631 / BSM 800 / BSM 1000 complies with protection requirements in regard to interference emission according to EN 61000-6-3:2007 (Interference emission for living-, commercial- and trade areas as well as for small business).

Therefore, the machine may be operated in industrial- as well as in living- and commercial areas.

4. Setup and function

4.1 Overview

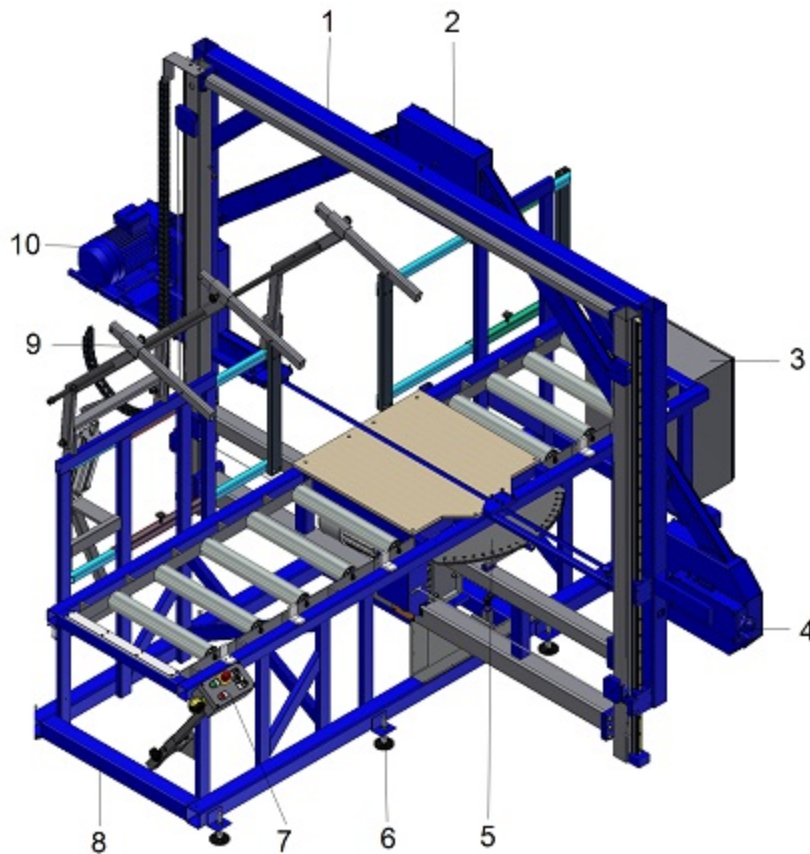

Fig. similar
Picture shows additional components

Pos.	Description
1	Saw frame
2	Saw bow
3	Switchboard cabinet
4	Tensioning device for saw band
5	Adjustment device for sawing angle
6	Screw foot
7	Control panel
8	Machine frame
9	Quick clamping device for work pieces (optional)
10	Motor saw band

4.2 Functionality

The BSM 631 / BSM 800 / BSM 1000 saws plastic pipes -

- with varying diameters,
- made of various types of plastic,
- with an adjustable saw angle.

The saw process is executed as follows:

- The desired saw angle is set
- The saw bow is raised.
- The workpiece is inserted into the machine and clamped.
- The saw bow with the running saw band is lowered with the configured feed rate. The workpiece is sawed off.
- The clamps on the workpiece are released, and the workpiece is removed from the machine.

4.3 Safety concept

4.3.1 Emergency-off circuit

The emergency-off circuit is activated by pressing the [Emergency-off button](#) on the control panel. Activating the [Emergency-off button](#) turns off the -

- saw-band motor and
- stroke drive of the saw bow



Caution!

Directly or indirectly touching live parts may result in electrocution.

The machine's power supply is *not* disconnected when the emergency-off circuit is activated. The main switch remains in the position *On*.

4.3.2 Safety button

According to valid APR the BSM 631 / BSM 800 / BSM 1000 must operate in jogging mode during processes that are dangerous for the operator. This means that the operator must press the buttons of the safety button with one hand while sawing. As soon as the buttons are released, the motor of the saw band and saw bow stops. This ensures that the operator is not in the hazard zone while the machine is sawing.

Against overloading by too high braking frequency, the device protects itself by an integrated control. For commissioning or for a adjusting 5 braking operations are admitted directly in succession. If an exceedance of the maximum allowable braking frequency is detected, the switch on the motor is locked. This lock can be reset only by switching off the machine.

Errors that occur during braking, are shown by a blinking mode on the brake device.

4.3.3 Further safety equipment

The BSM 631 / BSM 800 / BSM 1000 has additional safety equipment that automatically stops the motor of the saw band and saw bow when -

- the saw bow reaches the bottom stop

5. Delivery, in-company transport and storage

5.1 Delivery

- The BSM 631 / BSM 800 / BSM 1000 is delivered by a transportation company and off-loaded at the customer's operating site.
- The screwed-on feet of the BSM 631 / BSM 800 / BSM 1000 have been removed for transportation. The machine is transported partially disassembled and delivered upright on wooden blocks.

1) Immediately check the off-loaded machine for visible transportation damages. If the machine has been damaged, document the details and promptly report this to the transportation company and manufacturer.

2) Check also if the delivery contents of the BSM 631 / BSM 800 / BSM 1000 are complete (see Chap. 3.2 on p. 16).

5.2 Environmental conditions for storage and transport

Temperature	-10 to +40 degrees C
Relative humidity	15-55%, non-condensing



Attention!

Improper environmental conditions may cause damage to machine!

Protect the machine, and especially the electrical equipment, from moisture, rain and dust. The BSM 631 / BSM 800 / BSM 1000 may not be set up or stored outside.

5.3 In-company transport



Warning!

Crushing hazard for arms and legs during transport and machine setup!

- Only authorised persons may carry out the in-company transport and setup of the machine (see Chap. 2.5 on p. 10) according to valid APR.
- Also ensure that no persons are in the transportation path or in the setup area and wear safety shoes with toe-protection caps and a protective helmet.

**Attention!*****Improper transport may cause damage to machine!***

The BSM 631 / BSM 800 / BSM 1000 may not be lifted and transported with lifting devices that are attached to machine parts (e.g. the saw bow) but only with a suitable forklift that lifts the frame of the machine.

- 1) Provide a suitable forklift for the in-company transport of the machine.
- 2) Lift the machine frame centrally with the forklift.
- 3) Remove the underlying wooden blocks.
- 4) Transport the machine to the desired storage- or setup location.
- 5) Lay out the supplied wooden blocks at the storage- or setup location in such a manner so that the machine frame can rest securely on these.
- 6) With the forklift lower the machine onto the laid out wooden blocks. Ensure that the wooden blocks under the machine have been distributed evenly so the machine parts does not tip over.

6. Setup and activation

6.1 Setup location

6.1.1 Floor conditions



Warning!

Persons may be injured and the machine damaged if the floor in the setup room is not able to bear the machine's load!

Be aware of the following weights when determining the required load-bearing capacity:

- BSM 631 / BSM 800 / BSM 1000 during operation
- Workpieces (pipes)
- Operating personnel
- Lifting equipment for pipes
- Transportation devices for transporting the BSM 631 / BSM 800 / BSM 1000 to the setup location

The floor of the setup room for the BSM 631 / BSM 800 / BSM 1000 must have the following characteristics:

- Hard, level, without slope
- Sufficient load-bearing capacity
- No disruptive vibrations

The surface of the floor must have the following characteristics:

- Easy to clean
- Skid resistant

6.1.2 Lighting

The nominal lighting power at the setup location of the BSM 631 / BSM 800 / BSM 1000 must comply with valid workplace regulations.

6.2 Environmental operating conditions

Operating temperature	-10 to +40 degrees C
Relative humidity	15-55%, non-condensing
Height a. s. l.	1000 m
Max. Dust concentration	Legal regulations for workplace threshold values



Attention!

Improper environmental conditions may cause damage to machine!

- If the operating temperature exceeds the threshold temperature, the machine's setup room must be air-conditioned to avoid shutdown of electrical components.
- The proprietor is obligated to setup a properly dimensioned ventilation system at the setup site for sawing of glass fibre-reinforced plastics (GFP) or similar dusty work materials; in case of non-compliance, resulting machine damage is not covered under the guarantee.

6.3 Setup plan

Bild 1. Setup plan: View from top

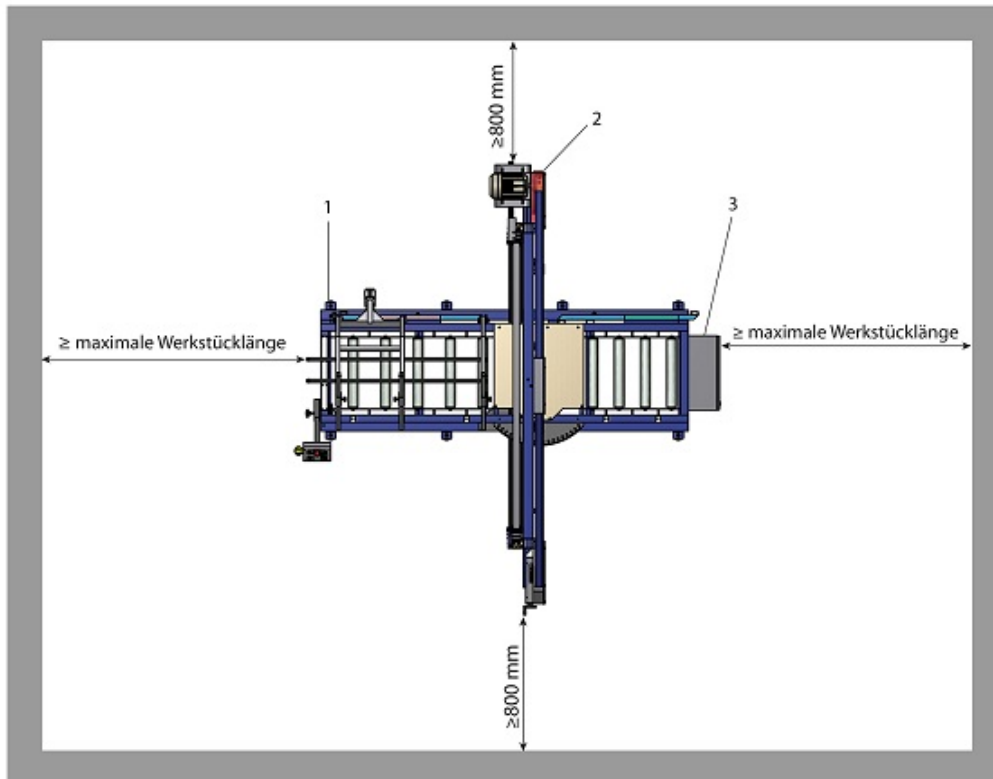

Fig. similar

Pos.	Description
1	Pneumatical connection (optional)
2	Connection suction saw shavings
3	Electrical connection (cable with plug)

Bild 2. Setup plan: View from side

Fig. similar

6.4 Setting up the machine

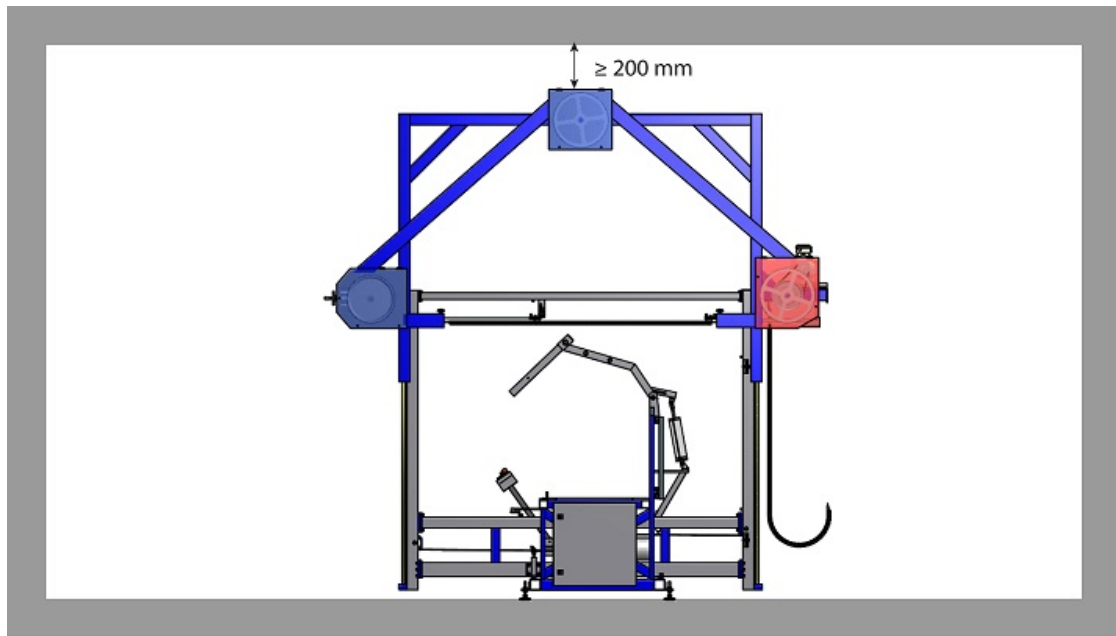

Warning!

Crushing hazard for arms and legs during transport and machine setup!

- Only authorised persons may carry out the in-company transport and setup of the machine (see Chap. 2.5 on p. 10) according to valid APR.
- The assembly of the BSM 631 / BSM 800 / BSM 1000 is carried out by qualified personnel of the manufacturer. The instructions of the service technician is to be unconditionally followed.
- Also ensure that no persons are in the transportation path or in the setup area and wear safety shoes with toe-protection caps.

1) Transport the BSM 631 / BSM 800 / BSM 1000 to the setup location (see Chap. 5.3 on p. 25). During setup pay attention to the required horizontal and vertical spacing (see Chap. 6.3 on p. 28).

2) Lift the BSM 631 / BSM 800 / BSM 1000 with a suitable transportation device.

3) Screw all supplied screw feet from below about half-way into the threaded holes of the machine frame (see Chap. 4. on p. 21).

4) Remove the underlying wooden blocks.

5) Slowly place the BSM 631 / BSM 800 / BSM 1000 on the ground until it fully rests on the screw feet.

- 6) Horizontally align the machine frame lengthwise and across with a water level. The slope of the machine frame can be adjusted by screwing the machine feet in or out.
- 7) Ensure that all screw feet are resting fully on the ground.
- 8) Secure the screw feet with the fitted locknut. This concludes machine setup.

6.5 Connect to electrical power supply



Warning!

Electrocution hazard!

Only professional electricians may connect the machine to the power supply according to the electro-technological regulations.



Caution!

Loosely laid cables are a tripping hazard!

Lay the power cable to the machine so that it does not pose a tripping hazard. E.g. cable bridges or connections along the ceiling can be used.



Attention!

Faulty connection values may cause material damage to machine!

Therefore, observe the machine's connection values (see Chap. 3.6 on p. 17).

- 1) Ensure that the cables that connect the BSM 631 / BSM 800 / BSM 1000 are equipped with an appropriately dimensioned circuit breaker.
- 2) Ensure that the phase sequence of the outer cable turns clockwise in the receptacle.
- 3) Connect the BSM 631 / BSM 800 / BSM 1000 to the power supply by connecting the machine's plug to a receptacle.

6.6 Establish pneumatic connection (optional)



Caution!

Loosely laid air pressure hoses may pose a tripping hazard!

Ensure that the laid-out air pressure hoses to the machine do not pose a tripping hazard. E.g. cable bridges or connections along the ceiling can be used.

- 1) Examine whether the pneumatic connection values at the setup location comply with required values (see Chap. 3.7 on p. 18).

2) Establish the pneumatic connection by connecting the plug coupling of an air pressure hose with the plug fitting behind the switchboard cabinet.

6.7 Connect to suctioning (optional)



Caution!

Loosely laid suction hose is a tripping hazard!

Lay the suction hose to the machine so that it does not pose a tripping hazard.
E.g. cable bridges or connections along the ceiling can be used.



Attention!

Not extracted shavings accumulate inside the machine and can impair the function of the BSM 631 / BSM 800 / BSM 1000!!!

Therefore, connect the BSM 631 / BSM 800 / BSM 1000 into an appropriate extraction system.



Attention!

An incorrectly routed suction hose can be damaged!

Therefore take into account when routing the suction hose, the vertical movements of the saw frame.

- 1) Ensure that the parameters of suction system consist required values (see Chap. 3.8 on p. 18)
- 2) Connect the BSM 631 / BSM 800 / BSM 1000 to the suction system by connecting suction hose with extraction nozzle.

6.8 Initial operation



Attention!

Warning against damage to machine's electrical equipment caused by condensation!

Wait several hours before turning on the main switch of the machine if there has been a sudden change in ambient temperature.

- 1) Set the machine up (see Chap. 6.4 on p. 29).
- 2) Remove the transport anchors at the saw bow.
- 3) Set the saw bow to 0 degrees

- 4) Connect pneumatic lines (optional)
- 5) Remove the transport anchors at the foot pedal (optional) and place it right from the control panel
- 6) Connect electrical power supply (see Chap. 6.5 on p. 30)
- 7) Make the connection to the suction (see Chap. 6.7 on p. 31)
- 8) Grease all blank machine guides (see Chap. 9.5 on p. 62).
- 9) Install a saw band if it has not yet been installed in the machine BSM 631 / BSM 800 / BSM 1000 (see Chap. 9.4 on p. 60)
- 10) Check all safety equipment (see Chap. 9.6 on p. 64).
- 11) Check whether all protective equipment is installed and connected (see Chap. 7.2 on p. 33).
- 12) Activate the BSM 631 / BSM 800 / BSM 1000 by turning the main switch on (see Chap. 7.3 on p. 33).

***Danger!******Running saw band may cause serious severance injury!***

- The machine may only be operated by one person.
- Before running the saw band, the operator must ensure that no persons are behind the workpiece or in the danger area.

- 13) Test to see whether the electrical connection is correct by observing the directional movement of the saw band:
 - a) If button **Control ON** is not lightening, then press it.
 - b) Press **Lift UP** and move saw band up about 50 cm.
 - c) On the control paneel press and hold both buttons of the **Save Ball** with one hand.
 - d) Release the buttons of the **Safe Ball** and determine the directional movement of the saw band.
 - The electrical connection is correct (see Chap. 1.6 on p. 7) if the saw band moves from the front of the machine to the back.
 - e) If the saw band moves from the back to the front, the electrical connection must be re-configured (see Chap. 6.5 on p. 30).
- 14) Finally, make a test cut (see Chap. 7.10 on p. 43).

7. Operation

7.1 Before start-up

Before start-up, check whether -

- 1) all protective equipment is properly installed and closed off (see Chap. 7.2 on p. 33);
- 2) all safety devices are functioning properly (see Chap. 9.6 on p. 64).

7.2 Protective equipment

How to check whether all protective equipment is properly installed and closed off:

- All saw-band covers mounted and fastened with screws? (see Chap. 9.3 on p. 58)
- Door of switchboard cabinet closed and locked?
- Sheet-metal cladding of saw-bow guides fastened with 6 screws (see Chap. 9.5 on p. 62)?

7.3 Turning the BSM 631 / BSM 800 / BSM 1000 on and off



Pos.	Description
1	Main switch
2	Switchboard cabinet

Fig. similar

Turning the BSM 631 / BSM 800 / BSM 1000 on

- 1) Turn the machine on by turning the [main switch](#) at the front switchboard cabinet counter-clockwise to the 12 o'clock position.
 - The writing "ON" becomes visible through the drill hole of the turning handle.

Turning the BSM 631 / BSM 800 / BSM 1000 off

1) Turn the BSM 631 / BSM 800 / BSM 1000 off by turning the **main switch** at the front switch-board cabinet clockwise to the 3 o'clock position.

- The writing "OFF" becomes visible through the drill hole of the turning handle.

7.4 Control panel

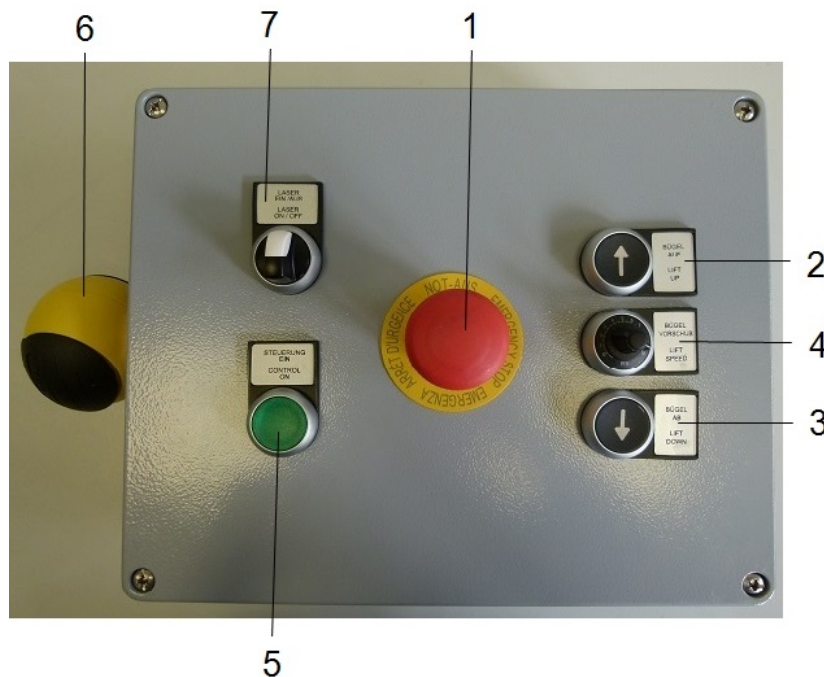

Fig. similar

Pos.	Description	Purpose
1	Emergency-off button	Stop the machine in an emergency
2	Button Lift up	Lifts up saw bow
3	Button Lift down	Lifts down saw bow
4	Adjuster Lift speed	Configure saw feed rate
5	Lamp button Control on	Power-up or after emergency stop switch on the control Lightening green = "Machine is ready to start"
6	Safe Ball	Sawing
7	Laser on / off (optional)	Activate and Deactivate Laser

7.5 Foot pedal (optional)



Pos.	Description	Purpose
1	Upper footswitch	open clamping device
2	Lower footswitch	close clamping device
3	Stopper	Stopper where the footswitch locks

7.6 Setting the saw feed rate



Warning!

A torn saw band or a saw band that jumped off the wheel poses an injury risk!

- If the saw feed rate is set too high, the saw band may jump off or tear.
- Always turn the dial **Lift speed** back to 1 *before sawing*.
- If you are sure that the initially set saw feed rate can be increased, do so slowly and in small increments during operation.



Optimal saw feed rate

The optimal saw feed rate depends on multiple factors:

- Material type of workpiece
- Wall thickness of workpiece
- Type of saw band
- Wear of saw band
- Required quality for the saw cut

Determine the optimal saw feed rate for each application case by slowly increasing the saw feed rate in small steps beginning with (1) while checking the quality of the cut. You can record the determined information in the table below to quickly find the optimal result in case you come across the same application case.

BSM 631 / BSM 800

DOWN SPEED	Saw feed rate mm/sec.	Material	Wall thickness, mm
1	3,0		
2	6,0		
3	9,0		
4	12,0		
5	15,0		
6	18,0		
7	21,0		
8	24,0		
9	27,0		
10	30,0		

BSM 1000

DOWN SPEED	Saw feed rate mm/sec.	Material	Wall thickness, mm
1	2,8		
2	5,6		
3	8,4		
4	11,2		
5	14,0		
6	16,8		
7	19,6		
8	22,4		
9	25,2		
10	28,0		

7.7 Setting the sawing angle



Pos.	Description
1	Angle scale
2	Reference pointer
3	Quick-tensioning lever

Fig. similar



Danger!

Running saw band may cause serious severance injury!

The swivel-mounted saw bow may pose pinch point hazard!

- The machine may only be operated by one person.
- The sawing angle may only be adjusted when the machine motor is turned off.
- Before setting the sawing angle, the operator must ensure that the area behind the workpiece and the work area are clear.
- The operator must ensure that saw band is above the workpiece.



Mitre cuts

The BSM 631 / BSM 800 / BSM 1000 has a mitre range of 45 degrees on both sides. This allows the operator to e.g. saw pipe segments without having to turn or move the workpiece.

- 1) If the saw band is below the upper workpiece edge, raise the saw bow by pressing and holding the button [Lift up](#) .
- 2) Press the [Emergency Off-Button](#), so no one accidentally turns on the machine motor.
- 3) Move possibly the right tension arm of the quick-release mechanism so far to the left or the left part of the pipe support to the right that they do not collide when setting the saw angle with the saw frame (see Chap. 7.8 on p. 38)

- 4) Ensure that there are no people or obstacles in the swivel range area of the saw frame.
- 5) Loosen the quick-tensioning lever on the saw-angle adjustment equipment.
- 6) Carefully and slowly swivel the saw frame in the appropriate direction until the reference pointer shows the desired angle value on the angle scale.
- 7) Secure the set angle position of the saw frame by tightening the quick-tensioning lever.
- 8) Unlock the [Emergency-Off-Button](#).

7.8 Loading the machine

Loading a workpiece into the machine

- 1) If the saw band is not raised, raise saw band up about 100 mm higher than the upper workpiece edge.
- 2) Press the [emergency-off button](#) so no one turns on the machine motor.
- 3) For the processing of pipes with max. Ø 200 mm mount the V-Support (optional).
- 4) Place the workpiece onto the support rolls of the machine with the help of a suitable lifting device and possibly another person.
- 5) Push the workpiece ahead as far as possible until the cutting line is under the saw band.
 - The optical cut indicator shows the cutting line on the workpiece (optional)
- 6) If the workpiece can not be safely clamped with minimum two tension belts, rotate the workpiece by 180 degrees in order to clamp it securely to the longer side. or take a longer workpiece.
- 7) When the workpiece is so long that it falls down without clamping, then you will support the outstanding workpiece end with suitable supports.
- 8) Set the movable support of the workpiece at the right side of the machine so that the workpiece is supported as close to the cutting line. Be advised by angle cuts, that the saw band does not collide with the movable support of the workpiece.
- 9) If necessary, set the space between saw band guide and workpiece (see Chap. 7.9 on p. 42).
- 10) Support protruding ends of long workpieces that tip down when clamped in.
- 11) Unlock the [emergency-off button](#).

Remove workpiece from the machine.

- 1) If the saw band remains below the upper workpiece edge, raise up the saw band about 100 mm higher than the workpiece edge. Use button [Lift up](#).
- 2) Press the [emergency-off button](#) so no one turns on the machine motor.
- 3) Release both tension belts and remove them from the workpiece and remove the workpiece and offcut from the machine with the help of a suitable lifting device and possibly another person.
- 4) Unlock the [emergency-off button](#).

Loading machine using the pneumatical pipe tensioning device (optional)



Fig. similar
Picture shows additional components

Fig. 1 Quick tensioning device

Pos.	Bezeichnung	Zweck
1	Tension arm left	Clamping workpiece
2	Thumb screw tension arm	Adjust tension arm
3	Tension arm middle	Clamping workpiece
4	Tension arm right (adjustable)	Clamping workpiece as close as possible to the cutting line
5	Thumb screw tension arm right	Adjust tension arm right
6	Support rolls	Support for the workpiece
7	Foot pedal	Close and open tension device

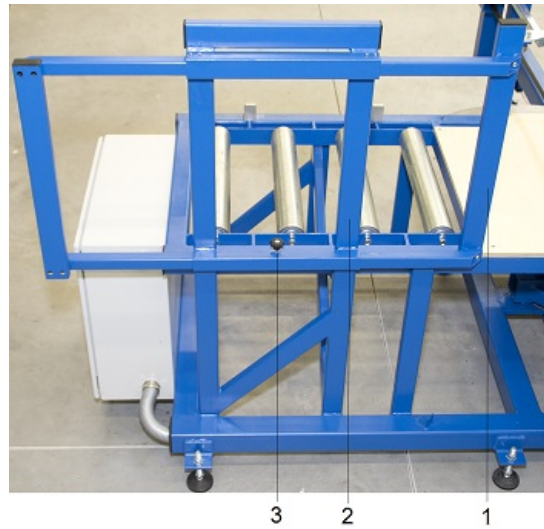

Fig. similar

Fig. 2 Right workpiece support

Pos.	Description	Purpose
1	Adjustable support	Support workpiece as close as possible at cutting line
2	Fixed support	Support workpiece
3	Thumb screw adjustable support	Lock adjustable support

***Warning!******Closing and opening the tension arms may cause pinch point injury!***

While closing or opening the tension arms with foot pedal, make sure that your hands or your assistant's keep hands away from moving area of clamping device.

***Attention!******Heavy workpieces may cause lifting injury!***

Use lifting gear such as a fork lift, hoisting crane, transport wagon etc. to load or remove workpieces into or from the machine.

***Attention!******Falling, offcut workpieces may injure the operator!***

Secure workpiece offcuts that are not clamped in (e.g. with suitable lifting gear) so that these pieces do not fall from the table after sawing.

**Attention!**

Sharp pipe edges and saw band may injure the operator!

Always wear protective gloves when loading the machine.

**Information!**

Important informations about the laser!

- The used laser is a laser class 1 according to DIN EN 60825-1:2008-05. The accessible laser radiation is harmless.

**Attention!**

Before sawing the workpiece with the machine, it must be securely tensioned with two tension belts.

Damage to the workpiece and the machine may result if the workpiece is not clamped in or clamped in insufficiently.

**Attention!**

Tension belts can be damaged or severed during angle cuts if they are placed in a wrong position.

When applying the belts, make sure that the tension belts are not in the path of the saw blade.

Loading a workpiece into the machine

- 1) If the saw band is not raised, raise saw band up about 100 mm higher than the upper workpiece edge.
- 2) Press the [emergency-off button](#) so no one turns on the machine motor.
- 3) For the processing of pipes with max. Ø 200 mm mount the V-Support (optional).
- 4) If not already done open clamping arms completely with foot pedal.
- 5) Place the workpiece onto the support rolls of the machine with the help of a suitable lifting device and possibly another person.
- 6) Push the workpiece ahead as far as possible until the cutting line is under the saw band.
 - The optical cut indicator shows the cutting line on the workpiece (optional)
- 7) To clamp the workpiece as close to the sawing position, loosen the screws and adjust the right clamping arm and fasten screw again. Be advised by angle cuts, that the saw band does not collide with the right clamping arm!
- 8) If the workpiece can not be safely clamped with minimum two tension belts, rotate the workpiece by 180 degrees in order to clamp it securely to the longer side. or take a longer workpiece.

- 9) When the workpiece is so long that it falls down without clamping, then you will support the outstanding workpiece end with suitable supports.
- 10) If necessary, adjust the length of all clamping devices to the diameter of the workpiece by loosening the screws, adjust the clamping device and tighten the screws.
- 11) Set the movable support of the workpiece at the right side of the machine so that the workpiece is supported as close to the cutting line. Be advised by angel cuts, that the saw band does not collide with the movable support of the workpiece.
- 12) Keep your hands away from the moving range of the clamping arms. Clamp the workpiece by pushing with the foot, the foot pedal bottom of the foot pedal up to the stop, so that it snaps into place.
 - The clamping arms move down and clamp the workpiece.
- 13) If necessary, set the space between saw band guide and workpiece (see Chap. 7.9 on p. 42)
- 14) Support protruding ends of long workpieces that tip down when clamped in.
- 15) Unlock the [emergency-off button](#).

Remove workpiece from the machine.

- 1) If the saw band remains below the upper workpiece edge, raise up the saw band about 100 mm higher than the workpiece edge. Use button [Lift up](#).
- 2) Press the [emergency-off button](#) so no one turns on the machine motor.
- 3) Open the clamping arms of the quick clamping device completely by pressing with the foot, the upper foot switch of the foot pedal, so that the lower foot switch returns to its starting position.
 - The clamping arms move up and release the workpiece freely
- 4) Remove the workpiece and offcut from the machine with the help of a suitable lifting device and possibly another person.
- 5) Unlock the [emergency-off button](#).

7.9 Space between saw-band guide and workpiece



Attention!

If the blade guides are set incorrectly, this can cause damage to the workpiece and the machine!

Adjust the saw-band guide before sawing so that they may not collide with the workpiece during the sawing operation.



Information

The minimum space between workpiece and saw-band guide should not be more than 50 mm; otherwise the quality of the saw-cut is compromised.

- 1) Press the **emergency-off button** so no one turns on the machine motor.
- 2) Load the machine with the workpiece to be sawed (see Chap. 7.8 on p. 38)
- 3) Turn on the star knob on the front an rear saw belt and adjust it (see Chap. 9.3 on p. 58)
- 4) Deactivate the **emergency-off button**.

7.10 Sawing



Danger!

Running saw band may cause serious severance injury!

Descending saw bow may pinch the operator!

- The machine may only be operated by one person.
- Before sawing, the operator must ensure that the area behind the workpiece and the work area are clear.
- Ensure that workpiece is fasten well before sawing operation



Attention!

Falling, offcut workpieces may injure the operator!

- Secure workpiece offcuts that are not clamped in (e.g. with suitable lifting gear) so that these pieces do not fall from the table after sawing.
- It is not permissible for the operator or the assisting person to hold or catch the offcut piece.

- 1) Turn on the machine with the **main switch**(see Chap. 7.3 on p. 33)
- 2) If required, set the desired sawing angle (see Chap. 7.7 on p. 37)
- 3) Load workpiece into machine (see Chap. 7.8 on p. 38)
- 4) Set the saw feed rate (see Chap. 7.6 on p. 35)
- 5) If lamp **Control on** is not lit, then press it.
- 6) On the control panel press and hold both buttons of the **Safe Ball** with one hand. You must keep these buttons pressed during the next two steps as the motors will otherwise stop abruptly.
 - The saw bow with the running saw band will move downward and execute the saw cut.
 - The motors stop automatically once the workpiece has been sawed and the saw bow has arrived at the bottom position.

- 7) If the desired cutting depth was achieved and the saw-band motor or saw-bow motor is still running, stop it by releasing the buttons of the [Safe Ball](#)
- 8) Raise the saw bow by pressing and press and hold the button [Lift up](#) until the saw band has been raised above the upper workpiece edge.
- 9) Remove the workpiece and offcut piece from the machine or position it anew if you wish to perform another cut on the same workpiece (see Chap. 7.8 on p. 38)
- 10) Begin again with Step 2) to execute another cut.



Information

If you want to interrupt the sawing process, just release the buttons for the [Safe Ball](#)

- The motors stop and the saw bow remains in the current position.

8. Finding and repairing malfunctions

8.1 Repairing mechanical malfunctions



Danger!

Running saw band may cause serious severance injury!

- Before repairing a malfunction, press the [Emergency-Off-Button](#) so the motors are not accidentally turned on.
- The malfunctions may only be repaired by one person at a time.

For the most part saw-band malfunctions occur while sawing. Go through the table from top to bottom when searching for the cause of the malfunction.

Malfunction	Cause	Corrective action
Saw band "displaced" or pushed up by the workpiece that is being sawed Saw band jumps off diversion-wheels Saw band torn	Saw-band tension not properly adjusted	Set proper saw-band tension (see Chap. 9.2 on p. 55)
	Saw feed rate too high	Reduce saw feed rate (see Chap. 7.6 on p. 35)
	Saw band dull	Exchange saw band (see Chap. 7.6 on p. 35)
	Saw band installed in wrong direction	Properly installing a saw band (see Chap. 9.4 on p. 60)
	Saw band does not have necessary properties.	Use original saw-band from the manufacturer (see Chap. 3.4 on p. 16)
	Workpiece has unsuitable material type (see Chap. 3.5 on p. 17)	Consultation with the manufacturer (see Chap. 11. on p. 71)
	Saw-band speed not correct	Check saw-band motor (see Chap. 8.3 on p. 47)
Saw band jammed in workpiece	Used wrong saw-band type	Consultation with the manufacturer (see Chap. 11. on p. 71)
	Frame under workpiece no longer flat	
The workpiece is not completely cut off, while the lower stop is reached.	Lower limit switch is displaced.	Set lower limit switch of the saw bow (see Chap. 8.4 on p. 48)
Quick clamping device can not open or close, though you have pressed the lower foot switch	No air pressure	Check air pressure
	Air pressure in the pneumatic system is too low	Provide sufficient air pressure in the pneumatic system (see Chap. 3.7 on p. 18)
The clamping arms of the quick clamping	Lower foot switch is not locked	Press the lower foot switch up to the stop, so that it locks into place

Malfunction	Cause	Corrective action
device open, once you release the lower foot switch		

8.2 Repair electrical malfunctions



Warning!

Electrocution hazard!

Only an electrician may repair an electrical malfunction of the machine's electrical equipment if these activities differ from operating tasks. The repair must be conducted according to electro-technological regulations.



Danger!

Running saw band may cause serious severance injury!

- Before repairing a malfunction press the [Emergency off button](#) so the motor is not accidentally turned on.
- The malfunction may only be repaired by one person at a time.

Go through the table from top to bottom when searching for the cause of the malfunction.

Malfunction	Cause	Corrective action
Lamp STEUERUNG EIN/AUS don't lighten, buttons are not functioning	Main switch turned off	Turn on main switch (see Chap. 7.3 on p. 33)
	The machine is not connected to power supply.	Connect machine to power supply (see Chap. 6.5 on p. 30)
	Power failure	Re-establish power supply
	Circuit breaker triggered in supply cable	Determine cause and activate circuit breaker
Lamp STEUERUNG EIN/AUS , buttons are functioning	Lamp defect	Exchange lamp
The saw-band motor or saw-bow motor cannot be activated.	Emergency off button pressed	Determine cause and unlatch Emergency off button
	Motor protection switch of the saw band triggered	Check motor protection switch -3F1 of saw-band motor

8.3 Check saw-band motor



Danger!

Running saw band may cause serious injuries!

Before checking the saw-band motor, turn off the machine at the main switch and secure it against re-activation.

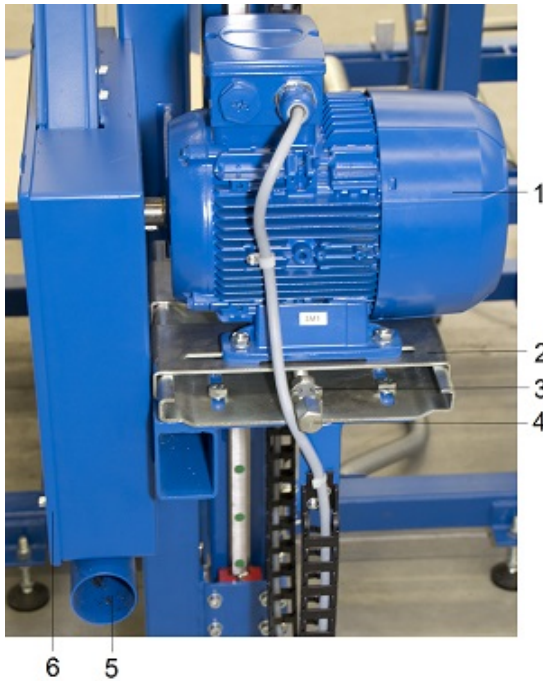

Pos.	Description
1	Motor saw band
2	Motor carriage
3	Inbus-screw
4	Shaft motor carriage
5	Extraction port sawdust
6	Back saw band cover

Fig. similar

- 1) If a workpiece is still in the machine, remove it (see Chap. 7.8 on p. 38).
- 2) Place the saw bow in the lowest position.
- 3) Turn the machine off at the main switch, and secure it against re-activation.
- 4) Remove the lower back saw-band cover.
- 5) Check the tension of the fan belt of the saw-band motor (see image in (see Chap. 9.2 on p. 55)).
- 6) If necessary, tension the fan belt by loosening both Allen safety screws and turn the shaft of the motor carriage in the appropriate direction with a suitable socket wrench.
- 7) Re-tighten the Allen safety screws after performing the adjustment.
- 8) Mount the removed saw-band cover at the right location.
- 9) Turn on the machine with the main switch.

8.4 Setting lower limit switch



Danger!

Running saw band may cause serious severance injury!

Descending saw bow may pinch the operator!

- The machine may only be set by one person.
- Before setting the limit switches, the operator must ensure that there is no person behind the work piece and the work area is clear of personnel.



Pos.	Description
1	Allen-screw
2	Stopper
3	Saw bow
4	Lower limit switch
5	Allen-screw
6	Saw frame

Fig. similar

- 1) If a workpiece is still in the machine, remove it or move the workpiece so that the saw frame can be shut down (see Chap. 7.8 on p. 38)
- 2) With Button [Lift down](#) place the saw bow in the lowest position.
- 3) Press [Emergency-Off-Button](#), so the motor is not accidentally turned on.
- 4) Loosen both fixing screws of the lower limit switch (on the rear side of the machine below the saw frame) and move the limit 1-2 millimeters down. Do not move the limit switch down too far, otherwise the saw band saws in the table.
- 5) Pull both locking screws securely.
- 6) Unlock [Emergency-Off-Button](#).
- 7) Check the lower limit switch is now set correctly. Saw off there to a workpiece completely, so that the machine stops automatically (see Chap. 1.1 on p. 1)
 - If the workpiece is now completely cut off, the limit switch is set correctly.
- 8) If the work is still not completely sawn through, repeat steps 1 to 7

8.5 Set optical cut indicator (optional)



Danger!

Running saw band may cause serious severance injury!

Descending saw bow may pinch the operator!

- Only one person may set the optical cut indicator.
- Before setting the optical cut indicator, the operator must ensure that the area behind the workpiece and the work area are clear.



Danger!

Climbing onto the machine poses a fall- and injury risk due to sharp machine parts!

It is not permissible to climb onto the machine when performing maintenance work. Use suitable climbing aids (e.g. stepladders or multi-purpose ladders, but no leaning ladders).



Information!

Important informations about the laser!

- The used laser is a laser class 1 according to DIN EN 60825-1:2008-05. The accessible laser radiation is harmless.

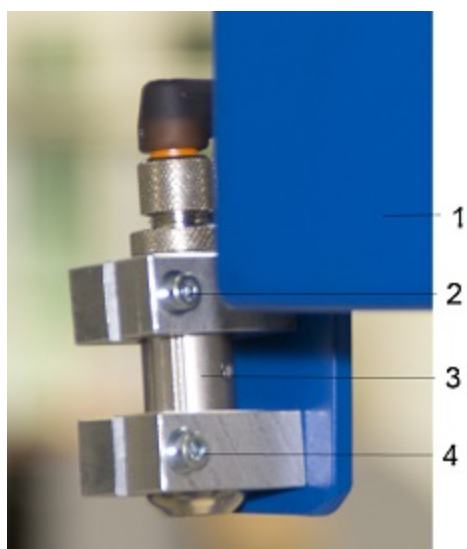

Pos.	Bezeichnung
1	Upper saw band cover
2	fixing screw
3	Laser diode
4	fixing screw

Fig. similar

If the laser beam of the optical cut indicator does not point directly to the cutting line on the workpiece or does not run parallel to the cut, adjust it as follows:

- 1) Execute a trial cut and leave the workpiece clamped into the machine (see Chap. 7.8 on p. 38)
- 2) If the saw bow is not at its lowest stop, then press button **Lift down** and drive the saw bow down.
- 3) Press the **Emergency-Off-Button**, so the motor is not accidentally turned on.
- 4) The optical cut indicator is located below the front bottom saw-band cover.
- 5) Use an Allen key to loosen both fastening screws of the laser diode bracket and turn the laser diode in order to position the laser beam parallel on the cut line.
- 6) Re-tighten the two fastening screws.
- 7) Remove the climbing aids
- 8) Unlock the **Emergency-Off-Button**. This concludes the adjustment of the optical cut indicator.

8.6 Guarantee

The manufacturer provides a guarantee for a 12-month term after the purchasing date according to legal and country-specific regulations. This means that damages to the machine that have resulted from material- or manufacturer errors are repaired free of charge. As a precondition for the guarantee, the machine must be cleaned and maintained on a regular basis.

The following issues are precluded from the guarantee:

- Damages to BSM 631 / BSM 800 / BSM 1000 which are the result of natural wear, overloading or improper handling; this especially refers to an improper operating environment.
- Damages caused by water, falls or non-legitimate interference with the inner mechanisms of the machine
- Damages to workpieces that have resulted from working with the BSM 631 / BSM 800 / BSM 1000
- Wearing parts such as drive belts, saw bands and carbon brushes of the motors and belt straps of the belt-lifting-system.

The manufacturer of the BSM 631 / BSM 800 / BSM 1000 is not liable for the quality of manufactured parts. The proprietor alone is responsible for quality control and the quality of parts manufactured with the machine.

9. Maintenance



Danger!

Running saw band may cause serious severance injury!

Descending saw bow may pinch the operator!

Only one person may perform maintenance while the machine is turned off (exceptions described in respective context).



Attention!

Perform all maintenance work thoroughly and on time!

All maintenance work in this manual must be performed thoroughly and on time to keep the machine operational with a high uptime.



Attention!

Only use original spare parts!

For reasons of personal safety and to ensure the proper functioning of the machine, you should only use original spare parts. It cannot be ensured that spare parts from other manufacturers are constructed with the necessary strain-bearing- and safety capabilities.

Activity	How often	Description
Clean the machine	Daily or after usage	(see Chap. 9.1 on p. 54)
Check saw-band tension	Weekly	(see Chap. 9.2 on p. 55)
Check safety equipment	Weekly	(see Chap. 9.6 on p. 64)
Check steel ropes of saw bow lift, if there are broken strands or splice	Weekly	In case of damage let change steel rope immediately by a service technician or authorised person
Grease machine	According to description	(see Chap. 9.5 on p. 62)
Check mechanical machine parts	yearly	Request service technician or authorised person
Clean belt straps	According to description	(see Chap. 9.1 on p. 54)
Check belt straps and replace if necessary	According to description	Request service technician or authorised person
DGUV Roule 3 examination (or applicable national regulation)	See DGUV Roule 3	Request service technician or authorised person
Examination according to IndSafReg §10 (2) (or according to national regulation)	Time limits according to § 3 Section 3 (Risk assessment)	Request service technician or authorised person

Before every maintenance activity (except for examination of safety equipment)

- 1) If a workpiece is still in the machine, remove it (see Chap. 7.8 on p. 38).
- 2) Place the saw bow in the lowest position.
- 3) Turn the machine off at the main switch, and ensure it is not activated again.

After every maintenance activity

Record performed activities (except cleaning) in the maintenance protocol (see Chap. 9.7 on p. 66).

9.1 Cleaning the machine



Attention!

Do not use compressed air to clean the machine!

Compressed air blows shavings and dust into the machine guides, bearings and electrical equipment. The machine may be damaged as a result.



Attention!

Plastic waste contaminates the environment!

Dispose of all shavings and plastic waste according to locally applicable legal stipulations.



Pos.	Description
1	Guide roll
2	Saw band
3	Guide roll

Fig. similar

Version with automatic air blow system (optional)

If the saw band begins to run, the system blows air onto the saw band to clean it from dust and shavings. However, this does not replace the regular additional cleaning of the guide rolls.

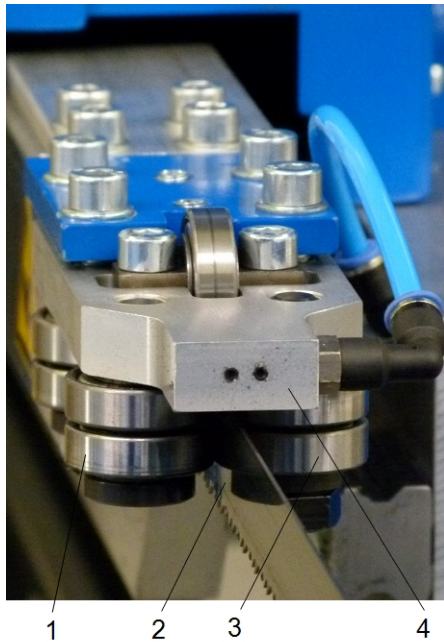

Pos.	Description
1	Guide roll
2	Saw band
3	Guide roll
4	Cleaning nozzle (covered)

Fig. similar

How to clean the machine

- 1) If you have not already done so, execute the steps in Chap. 9. on p. 53 .
- 2) Remove shavings from machine parts with a hand broom, brush or vacuum cleaner.
- 3) Use a brush to remove the shavings in the guide rolls at the saw-band guide.
- 4) Clean up the shavings and plastic waste on the ground with a broom or vacuum cleaner.

9.2 Tensioning the saw band



Danger!

If the saw band tears or jumps off, it may injure the operator!

- The saw band may only be tensioned while the machine is idle.
- If the saw band is tensioned improperly, it may tear or jump off the diversion-wheels during sawing. Adhere to the optimal tensioning values.
- Use original saw bands from the machine's manufacturer as it cannot be ensured that saw bands from other manufacturers are safe for usage or have the proper strain capability.

**Attention!****Warning of material damage to machine or workpiece!**

Ensure an optimal tensioning of the saw band as it might otherwise tear or jump off the guide wheels and damage either the machine or the workpiece.

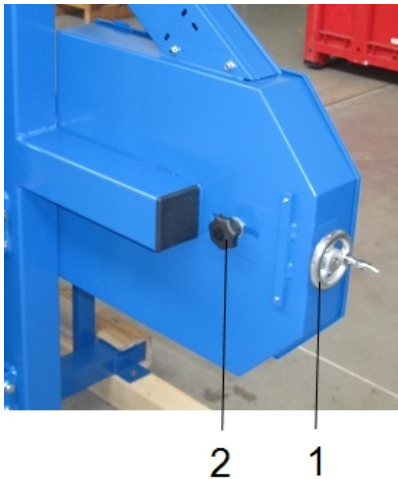
How to tension the saw band of the BSM 631

Pos.	Bezeichnung
1	Hand wheel
2	Star knob for locking

To achieve a good cutting performance with slanted cuts, proper belt tension is very important. The blade tension is controlled pneumatically. The correct operating pressure for the blade tension is 2.5 - 3 bar. A pneumatic shut-off valve maintains the tape under tension, for the case that the compressed air is failed.

**Information**

- Since the length of the saw band varies due to manufacturing tolerances and temperature fluctuations, you must find the optimal tension for the saw band while working with the machine.

- 1) If you have not already done so, execute the steps in Chap. 9. on p. 53.
- 2) Release star knob.
- 3) If the saw band tension is too weak (poor cut quality, saw band bounces off the reversing wheels, etc.), then you turn the handwheel clockwise until it is optimally tensioned.
- 4) If the saw band tension is too strong (saw band breaks), then turn the knob counter-clockwise until it is perfectly tensioned.
- 5) Turn back star knob to fasten saw band tension.

How to tension the saw band of the BSM 800 / BSM 1000

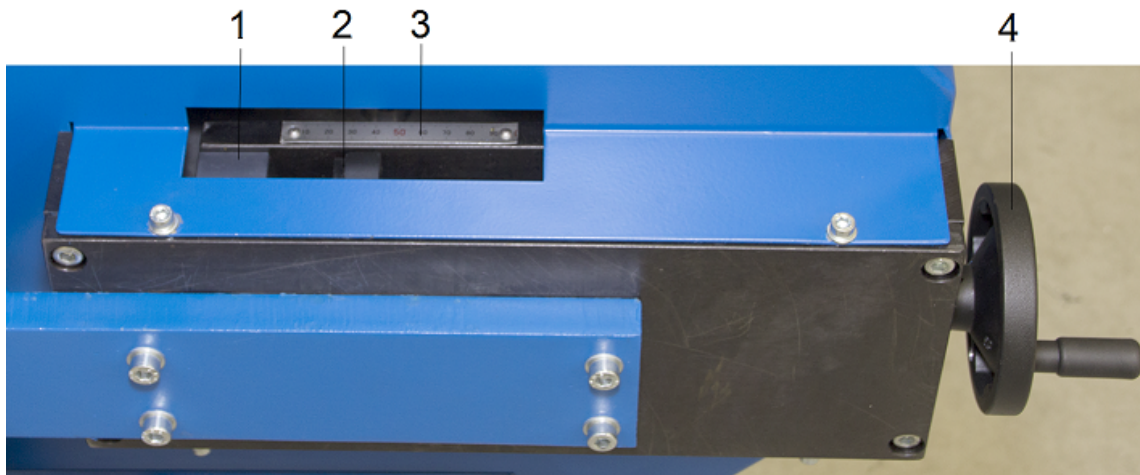

Pos.	Description
1	Left stopper
2	Reference edge
3	Scala
4	Hand wheel



Information

- Since the length of the saw band varies due to manufacturing tolerances and temperature fluctuations, you must find the optimal tension for the saw band while working with the machine.
- The saw band is optimally tensioned when the reference mark is located between the values 45 and 55 on the scala.
- The band-tensioning device automatically balances out the warmth-induced expansion during sawing.

- 1) If you have not already done so, execute the steps in Chap. 9. on p. 53.
- 2) If the saw band tension is too weak (poor cut quality, saw band bounces off the reversing wheels, etc.), then you turn the handwheel clockwise until it is optimally tensioned.
- 3) If the saw band tension is too strong (saw band breaks), then turn the knob counter-clockwise until it is perfectly tensioned.

9.3 Removing the saw band

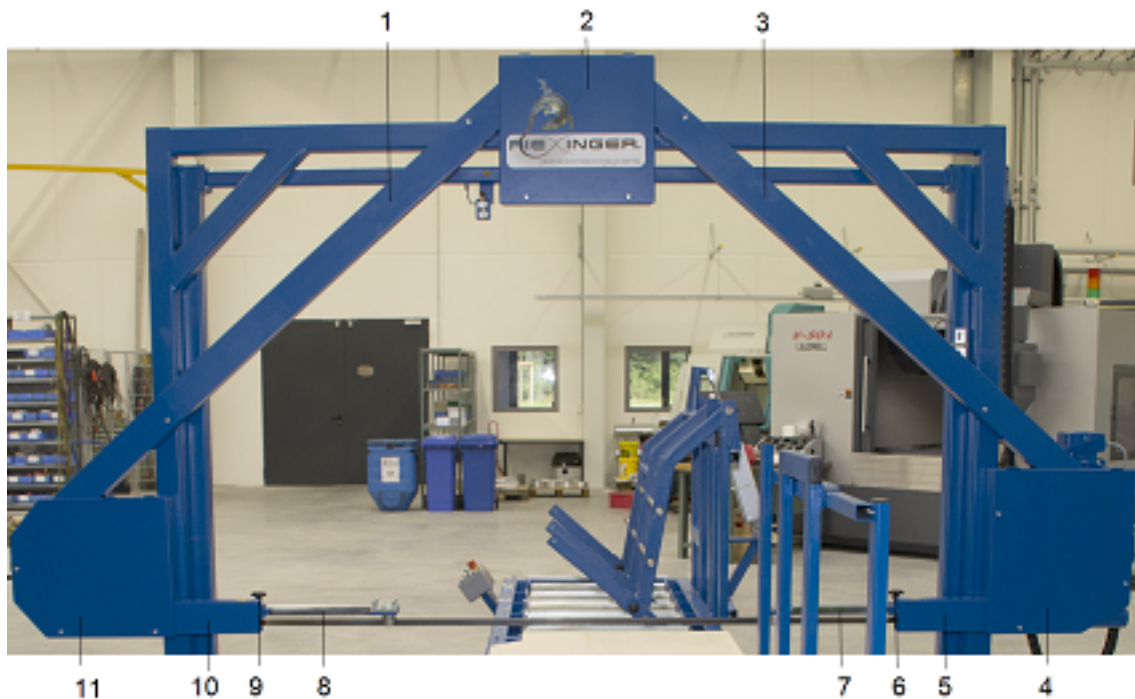

Pos.	Description
1	Diagonale saw band cover in front
2	Upper saw band cover
3	Diagonale saw band cover behind
4	Lower saw band cover behind
5	Short saw band cover behind
6	Fasten-screw for saw band guide behind
7	Adjustable saw band guide behind
8	Adjustable saw band guide in front
9	Fasten-screw for saw band guide in front
10	Short saw band cover in front
11	Lower saw band cover in front



Danger!

Running saw band may cause serious severance injury!

Descending saw bow may pinch the operator!

The assisting person mentioned below may only enter the hazard- or working area after deactivating the machine with the main switch.

***Danger!***

Climbing onto the machine poses a fall- and injury risk due to sharp machine parts!

It is not permissible to climb onto the machine when performing maintenance- or any other kind of work. Use suitable climbing aids (e.g. stepladders or multi-purpose ladders, but no leaning ladders).

***Attention!***

After sawing the hot saw band may burn the operator!

The saw band poses an injury risk!

Wear protective gloves when working with the saw band and let the saw band cool down before touching it.

- 1) If you have not already done so, execute the steps in Chap. 9. on p. 53
- 2) Keep appropriate climbing aids on hand.
- 3) Relax the saw band by turning the handwheel counter-clockwise until the movable part comes up against the reference edge at the back stop (see Chap. 9.2 on p. 55) This makes it easy to later on remove the saw band by hand from the diversion wheels.
- 4) Call on an instructed assistant for assistance with the next steps. The assisting person can e.g. execute the same movements at the back of the machine as the operator in the front.
- 5) Operator and assisting person are required to wear work gloves and safety glasses.
- 6) Disassemble all covers of the saw band.
 - Lower saw band covers front and rear (each with 3 screws)
 - Upper saw band cover (2 screws)
 - Diagonal saw band cover front and rear (each with 2 screws)
- 7) Carefully pull off the saw band from the diversion wheels in front and rear (see illustration Chap. 1.1 on p. 1)
- 8) Carefully pull off the saw band from the front and back saw-band guide .
- 9) Use climbing aids to pull off the saw band from the upper diversion wheel .

***Warning!***

Coiling up the old saw band poses an injury risk - especially for the facial area!

Operator and assisting person must be especially careful and wear protective glasses.

- 10) Coil up the old saw band to safely dispose of it.
- 11) Remove all saw dust with a brush or vacuum cleaner from where the saw band used to run. The installation of a new saw band is explained in Chap. 9.4

9.4 Inserting the saw band



Danger!

Running saw band may cause serious severance injury!

Descending saw bow may pinch the operator!

The assisting person mentioned below may only enter the hazard- or working area after deactivating the machine with the main switch.



Danger!

Climbing onto the machine poses a fall- and injury risk due to sharp machine parts!

It is not permissible to climb onto the machine when performing maintenance- or any other kind of work. Use suitable climbing aids (e.g. stepladders or multi-purpose ladders, but no leaning ladders).



Attention!

After sawing the hot saw band may burn the operator!

The saw band poses an injury risk!

Always wear protective gloves when working on the saw band.



Fig. similar

Pos.	Bezeichnung
1	Upper diversion wheel
2	V-blet saw band motor
3	Rear diversion wheel
4	Rear saw band guide
5	Front saw band guide
6	Diversion wheel front

- 1) Keep appropriate climbing aids on hand.
- 2) If you have not already done so, execute the steps in Chap. 9. on p. 53
- 3) If the covers of the saw band have not already been removed, do so(see Chap. 9 on p. 53)
- 4) Call on an instructed assistant for assistance with the next steps. The assisting person can e.g. execute the same movements at the back of the machine as the operator in the front.
- 5) Operator and assisting person are required to wear work gloves and safety glasses.



Warning!

Uncoiling the old saw band poses an injury risk - especially for the facial area!

Operator and assisting person must be especially careful and wear protective glasses.

- 6) Carefully uncoil the band.
- 7) Use the climbing aids and insert the saw bow into the upper channel so that the saw-band teeth point in the cutting direction at the bottom.
- 8) Insert the saw band around the both saw-band diversion-wheels. Ensure that the saw band is placed centrally on the diversion-wheels.
- 9) Insert the saw band in front and behind through the both guide-roll pairs.(see illustration in Chap. 1.1 on p. 1 Note that the saw band must be turned 90 degrees between the lower diversion-wheel and the guide-roll pair.
- 10) Tension the saw band (see Chap. 9.2 on p. 55)
- 11) Check whether the saw band is placed centrally on all diversion-wheels and runs through the guide-roll pair.
- 12) Check whether the saw band runs properly by carefully spinning the diversion-wheel clockwise.
- 13) Mount the removed saw-band covers at the right location and close the door of the housing on both sides.
 - Diagonal saw band covers front and rear (each 2 screws)
 - Upper saw band cover (2 screws)
 - Lower saw band covers front and rear (each 3 screws)

14) Remove all climbing aids and other objects from the work area. The assisting person must also clear the area.

15) Perform a test cut (see Chap. 7.10 on p. 43) and adjust the saw-band tension if necessary

9.5 Greasing



Danger!

Climbing onto the machine poses a fall- and injury risk due to sharp machine parts!

It is not permissible to climb onto the machine when performing maintenance work. Use suitable climbing aids (e.g. stepladders or multi-purpose ladders, but no leaning ladders).

How to prepare the machine for greasing:

- 1) Keep appropriate climbing aids on hand.
- 2) If you have not already done so, execute the steps in Chap. 9. on p. 53.

Lubrication plan saw bow

1) Grease the linear guides and ballscrews according to the lubricating instructions of HIWIN company.

Pos.	Description	Grease gun	Grease spray	How often
S1, S4	Lower saw bow guides back and front (grease fittings)	x		monthly
S2, S5	Upper saw bow guides back and front (grease fittings)	x		monthly
S3, S6	linear guides, back and front		x	monthly

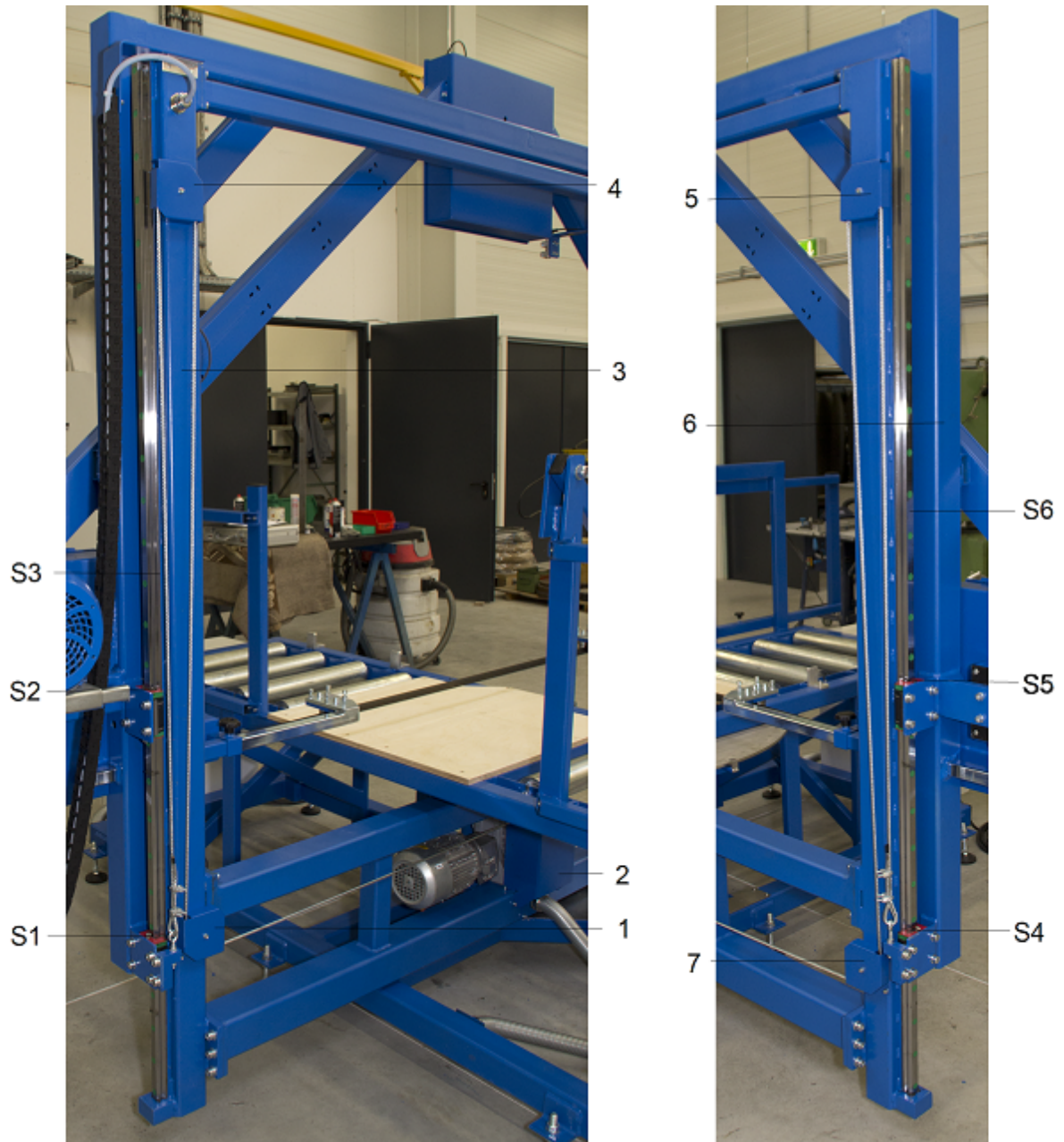

Pos.	Description
1	Rear rope cover below
2	Rope cover on the gearbox
3, 6	saw bow
4	Rear rope cover above
5	Front rope cover above
7	Front rope cover below

9.6 Check safety equipment



Danger!

Running saw band may cause serious severance injury!

Descending saw bow may pinch the operator!

Only one person may check the machine's safety equipment.

How to check the main switch

- 1) If a workpiece is still in the machine, remove it (see Chapter. 1.1 on p.1).
- 2) Turn on the machine off with the **main switch**(see Chapter 1.1 on p.1).
- 3) Sequentially press multiple buttons on the control
 - The lamp **Control ON** should not be lit.
 - It should not be possible to activate the machine drives even when the safety button is active and the **emergency-off** is unlocked.
- 4) If the machine does not respond as described above when the **main switch** is deactivated, it is not permissible to use the machine until this defect has been repaired by an electrician.

How to check the safety button

If a workpiece is still in the machine, remove it (see Chapter. 1.1 on p.1).

- 1) Turn on the machine with the **main switch** (see Chapter 1.1 on p.1).
- 2) Press and hold both buttons of the **Emergency-Off-Button**.
 - Sawing begins.
- 3) Release the button for the **Safe Ball**.
 - Sawing must stop immediately.
- 4) If sawing does not stop immediately or if sawing starts while the safety switch is not activated, turn off the machine with the **main switch** and contact the manufacturer's customer service (see Chapter 1.1 on p.1).

How to check the emergency-off button

- 1) If a workpiece is still in the machine, remove it (see Chapter 1.1 on p.1).
- 2) Turn on the machine with the **main switch** (see Chapter 1.1 on p.1).
- 3) Press and hold both buttons of the **Safe Ball** with one hand.
 - Sawing begins
- 4) Press the **Emergency-Off-Button**
 - Sawing must stop immediately.
- 5) Press the button **Lift up** or **Lift down**.
 - It should not be possible to start the saw-band motor.

6) Unlock the [Emergency-Off-Button](#)

7) If the drives can be started while the [emergency-off](#) is activated or if the drives do not stop immediately, turn off the machine with the main switch and contact the manufacturer's customer service (see Chapter 1.1 on p.1).

10. Dismantling and disposal

10.1 Deactivation

***Danger!******Running saw band may cause serious severance injury!******Descending saw bow may pinch the operator!***

Only an authorised person may deactivate the machine (see Chap. 2.5 on p. 10).

How to deactivate the BSM 631 / BSM 800 / BSM 1000:

- 1) If a workpiece is still in the machine, remove it (see Chap. 7.8 on p. 38).
- 2) Place the saw bow in the lowest position.
- 3) Turn the machine off at the [main switch](#), and ensure it is not activated again.
- 4) Pull the power plug-in out of the receptacle.
- 5) Disconnect the machine from the air pressure supply by pulling off the plug-in coupling from the machine's plug-in fitting (see Chap. 6.6 on p. 30).
- 6) If the machine is transported to a different location, set the saw bow to 45 degrees (see Chapter 1.1 on p.1).
- 7) Secure the saw bow and the swivel-mounted control panel with transport anchors before transport (e.g. appropriate cable straps).

10.2 Final shutdown

- 1) Execute the steps from the previous section.
- 2) Disconnect the power supply cable to the machine so that unauthorised persons cannot activate the machine.

10.3 Disposal

***Danger!******Climbing onto the machine poses a fall- and injury risk due to sharp machine parts!***

Workers may not climb onto the machine even when disposing of it. Use suitable climbing aids (e.g. stepladders or multi-purpose ladders, but no leaning ladders).

**Information!*****Saw bow to deposite!***

The BSM 631 / BSM 800 / BSM 1000 is equipped with a saw bow to deposite. Lay down the saw bow when disposing the machine. There are usually no climbing aids necessary.

**Warning!*****Crushing hazard for arms and legs during transport of machine!***

- The in-company transport may only be conducted by authorised persons (see Chap. 2.5 on p. 10) according to valid APR.
- Also ensure that no persons are in the transportation path or in the setup area and wear safety shoes with toe-protection caps.

**Attention!*****According to EU regulations machine parts may not be discarded with unsorted household garbage!***

During disposal separate the individual types of materials and dispose of them in accordance with country-specific regulations.

**Information**

The BSM 631 / BSM 800 / BSM 1000 does not contain dangerous materials

The following rules must be observed when disposing of the machine at the end of its lifecycle:

- Adhere to the country-specific regulations regarding disposal of industrial machines
- If unsure, contact a professional disposal company
- Separate plastics from metal and dispose of these materials separately
- Dispose of seals and rubber parts as special waste
- Also dispose of electrical motors and electrical components such as controls, switches and cables separately

11. Annex

11.1 Contact form

This is our contact address:
 Eugen Riexinger GmbH & Co. KG
 Egartenring 2
 75378 Bad Liebenzell-Unterhaugstett
 Germany
 Phone +49 (7052) 930 90-0
 Fax +49 (7052) 930 90-33
 Email info@riex.de
 Internet www.riex.de

Tell us about your experience with the BSM 631 / BSM 800 / BSM 1000 or make some suggestions for improving either the BSM 631 / BSM 800 / BSM 1000 or this operating manual. Copy, fill out and send us this contact form. We want to thank you in advance for your assistance!

- Serial number of deployed BSM 631 / BSM 800 / BSM 1000.....
- We primarily use the BSM 631 / BSM 800 / BSM 1000 for the following materials/workpieces:

Experiences/Suggestions for improvement

.....

Date Name:

11.2 EC Conformity Declaration

according to EC Machine Guideline 2006/42/EG, Annex II A

We hereby declare that the machine distributed by us and described in the following conforms to the basic safety- and health requirements of the EC Guideline 2006/42/EG in regard to its conception and design. This declaration loses its validity if the machine is changed without our consent.

Manufacturer:

Eugen Riexinger GmbH & Co. KG
plasticconnectingsystems
Egartenring 2
75378 Bad Liebenzell-Unterhaugstett
Germany

Person authorised to compile the technical file:

Markus Theobald (Business Manager), Eugen Riexinger GmbH & Co. KG, Egartenring 2, 75378 Bad Liebenzell

Description of machine:

Band-saw machine for plastic pipes of type BSM 631 / BSM 800 / BSM 1000

A conformity declaration is also made for other valid product-relevant guidelines.

- Guideline 2014/30/EU (EMC guideline)
- Guideline 2011/65/EG (RoHS guideline)
- The safety objectives of European Directive 2014/35/EU (low voltage guideline) comply with machine guideline Annex I, Section 1.5.1

Applied and harmonised norms:

- DIN EN ISO 12100:2010 Machine safety - General design principles - Risk evaluation and risk reduction
- DIN EN ISO 13849-1:2008 Machine safety - Safety-relevant control parts - Part 1: General design principles
- DIN EN ISO 13850: 2009 Machine safety - Emergency Stop - Safety-relevant control parts
- DIN EN ISO 13857:2008 Machine safety - Safety spacing for hazardous proximity of arms and legs
- DIN EN 60204-1:2006 Machine safety - Electrical equipment of machines, Part 1: General requirements
- DIN EN 61000-6-2:2005 Interference stability for industrial areas
- DIN EN 61000-6-3:2007 Interference emission for living-, commercial- and trade areas as well as for small business

Bad Liebenzell, 14.04.2016

Markus Theobald (Business Manager)



11.3 Dimension sheets

11.3.1 Dimension sheet BSM 631

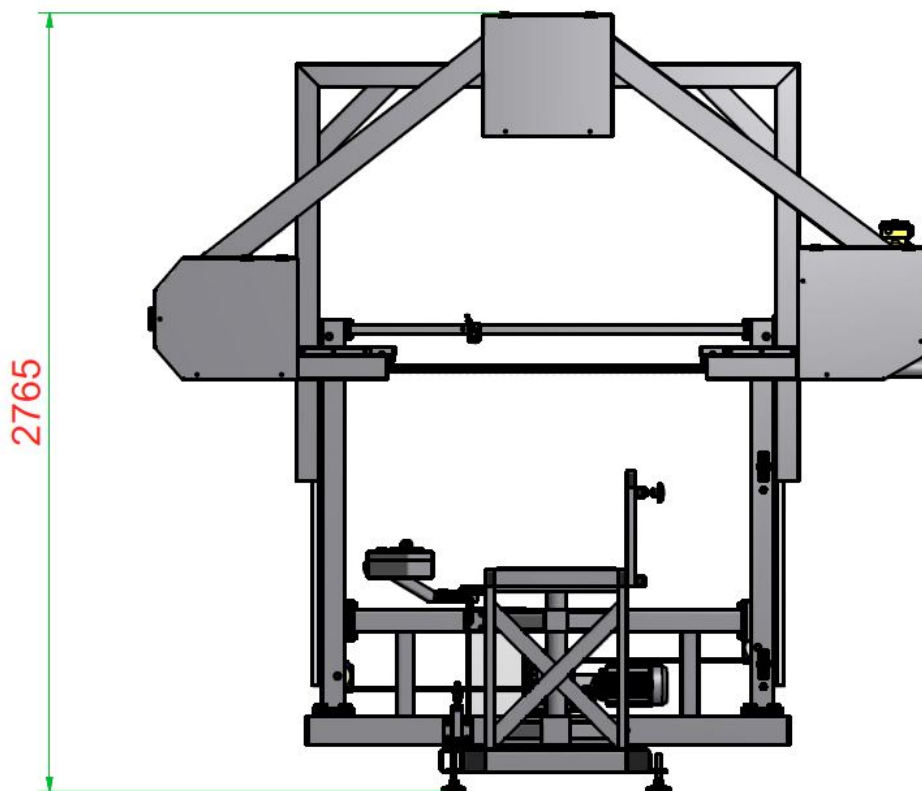
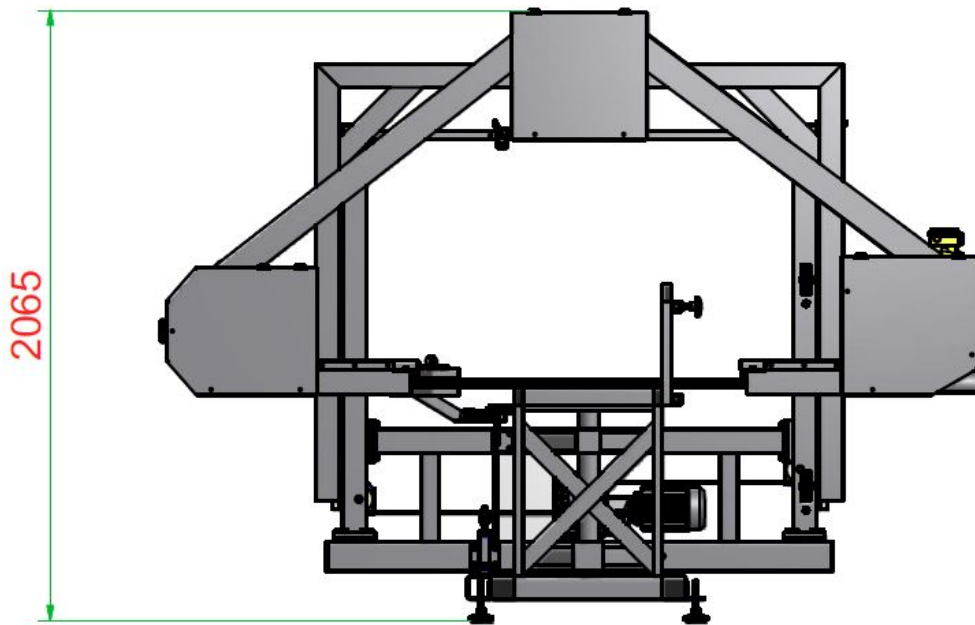

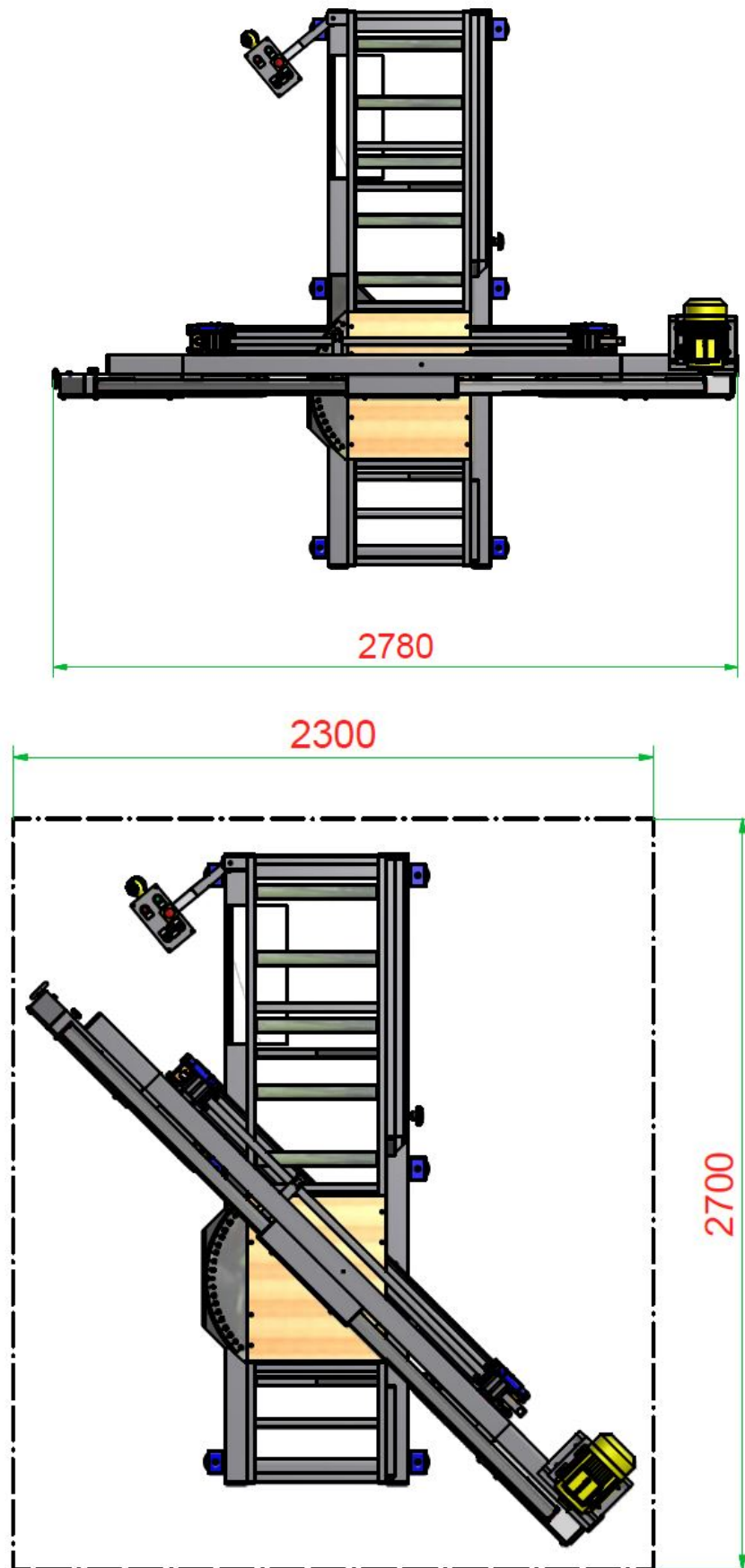

11.3.2 Dimension sheet BSM 800

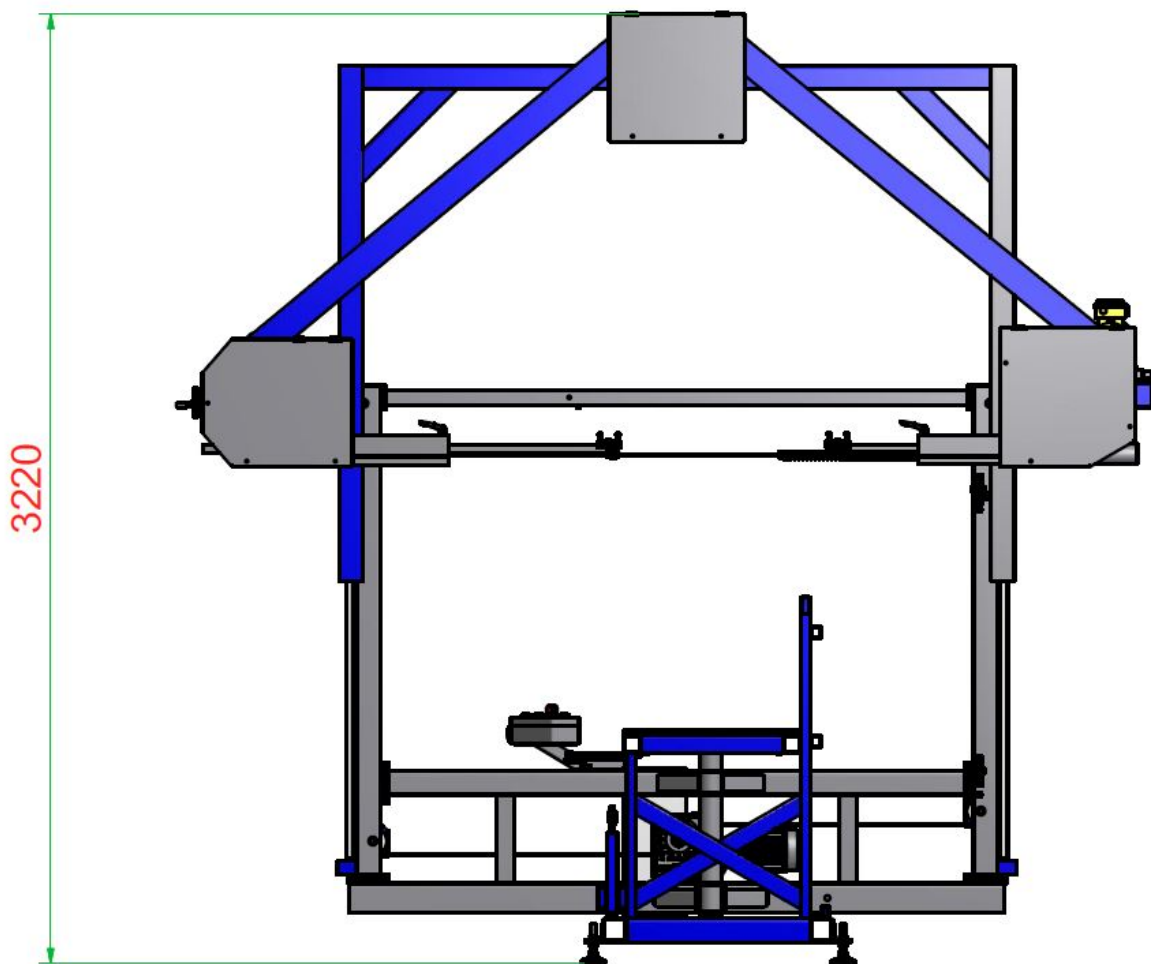
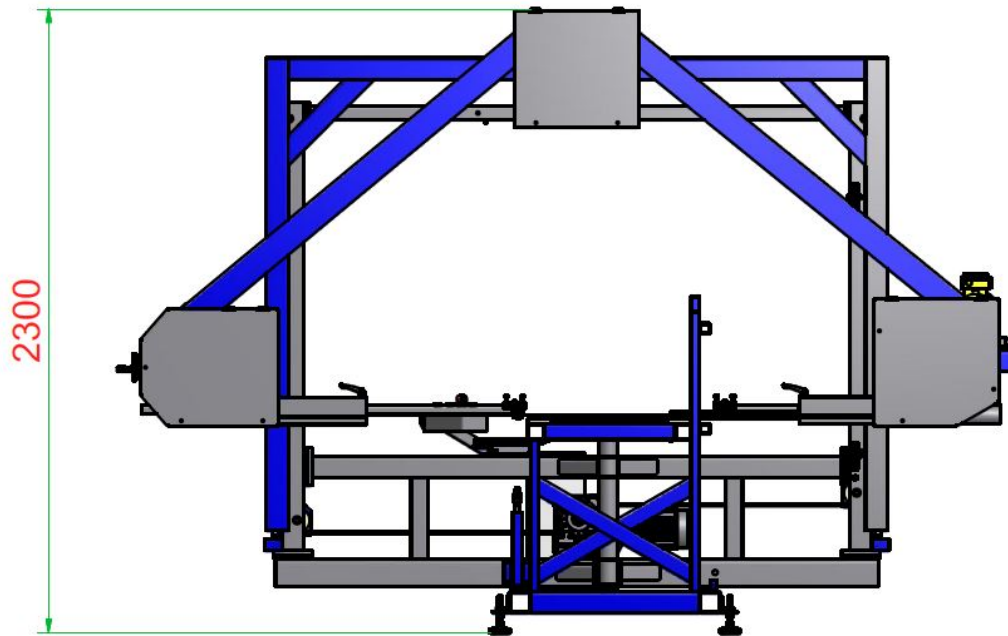

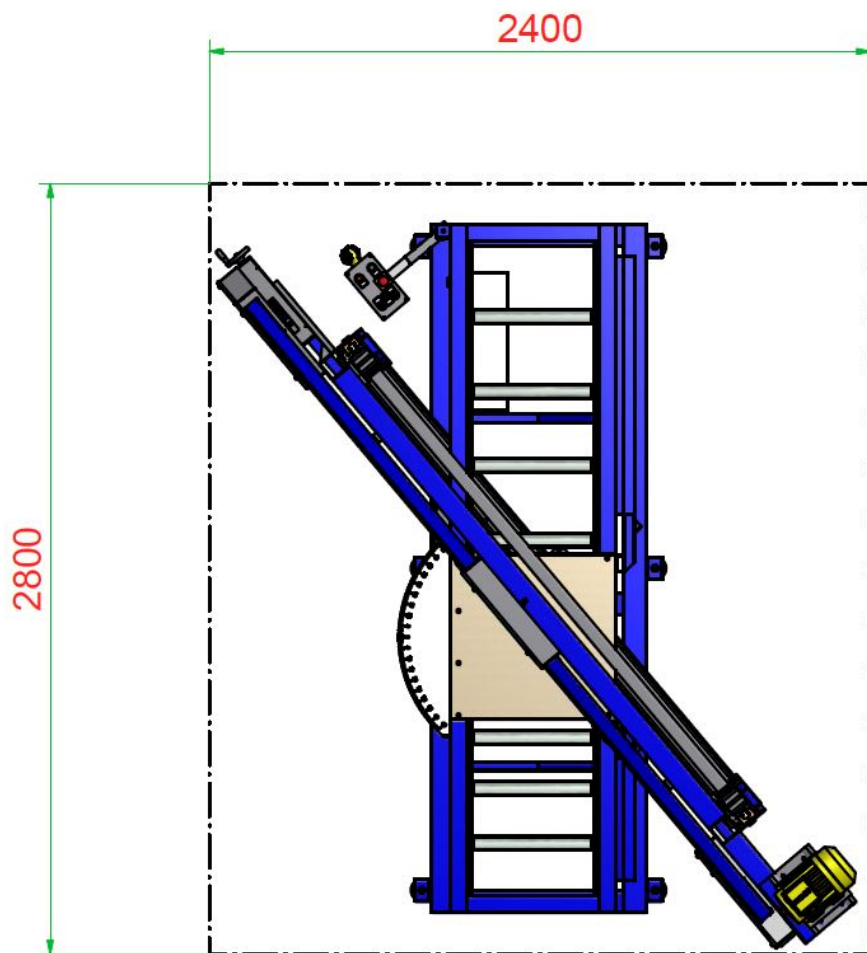
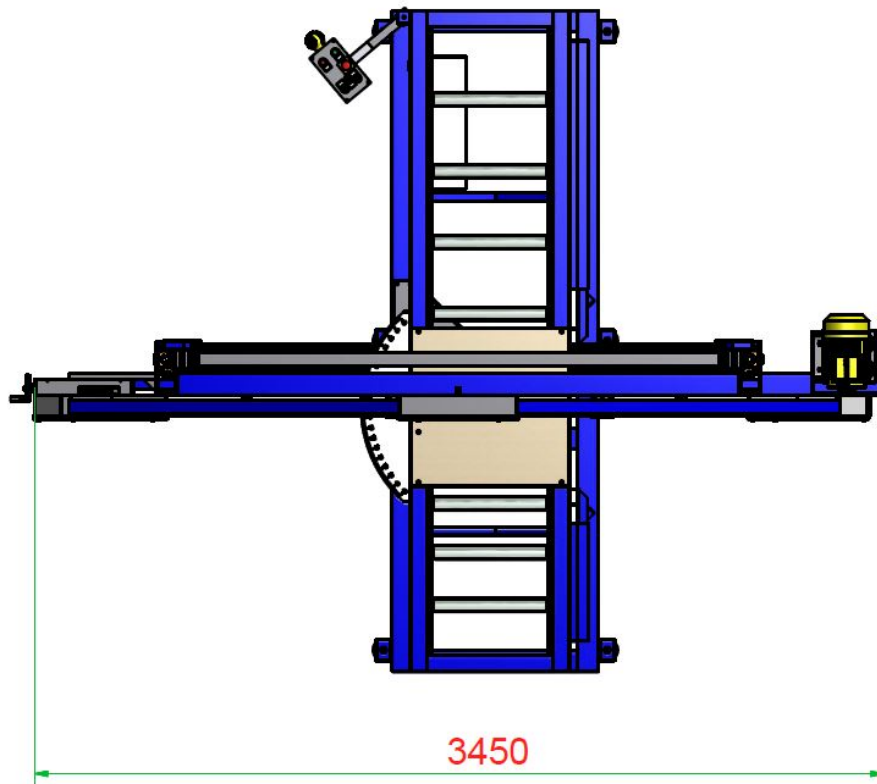

11.3.3 Dimension sheet BSM 1000

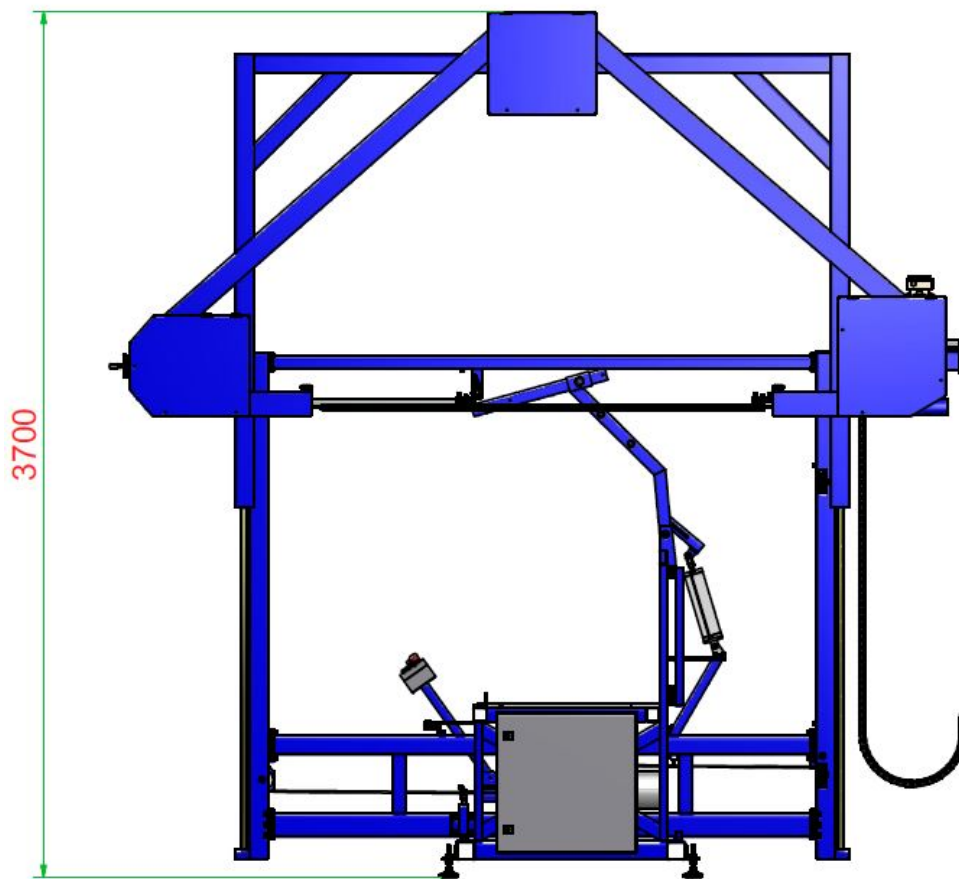
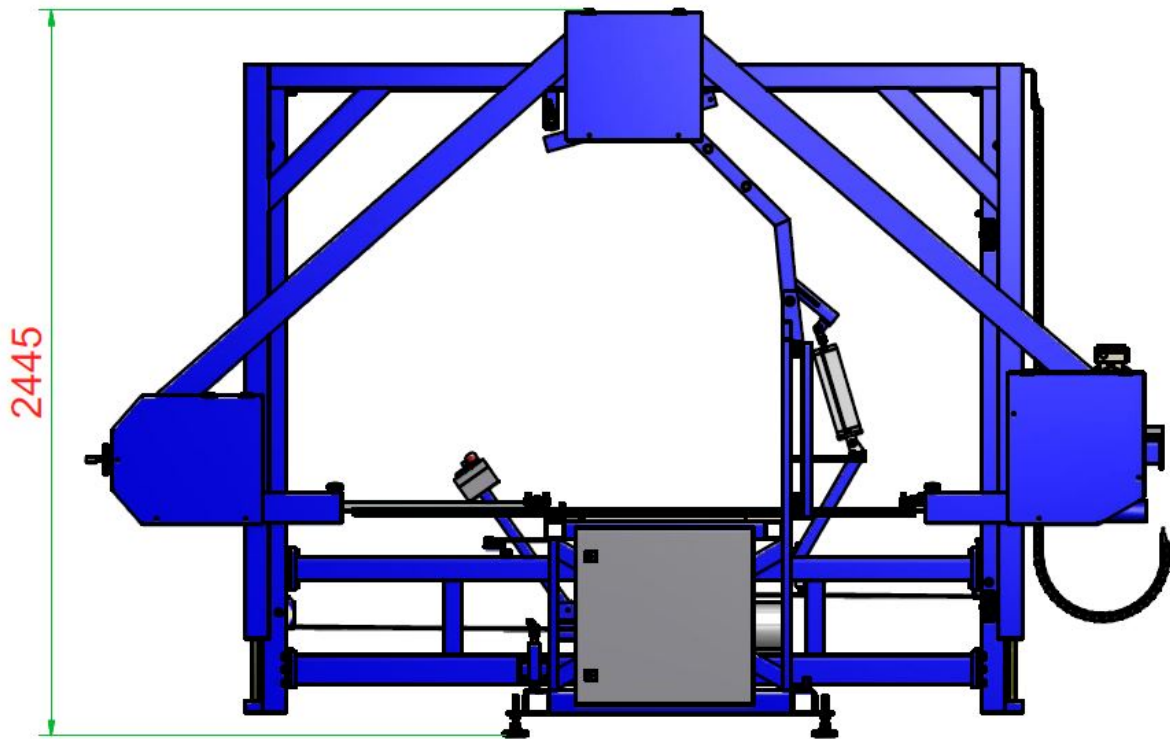

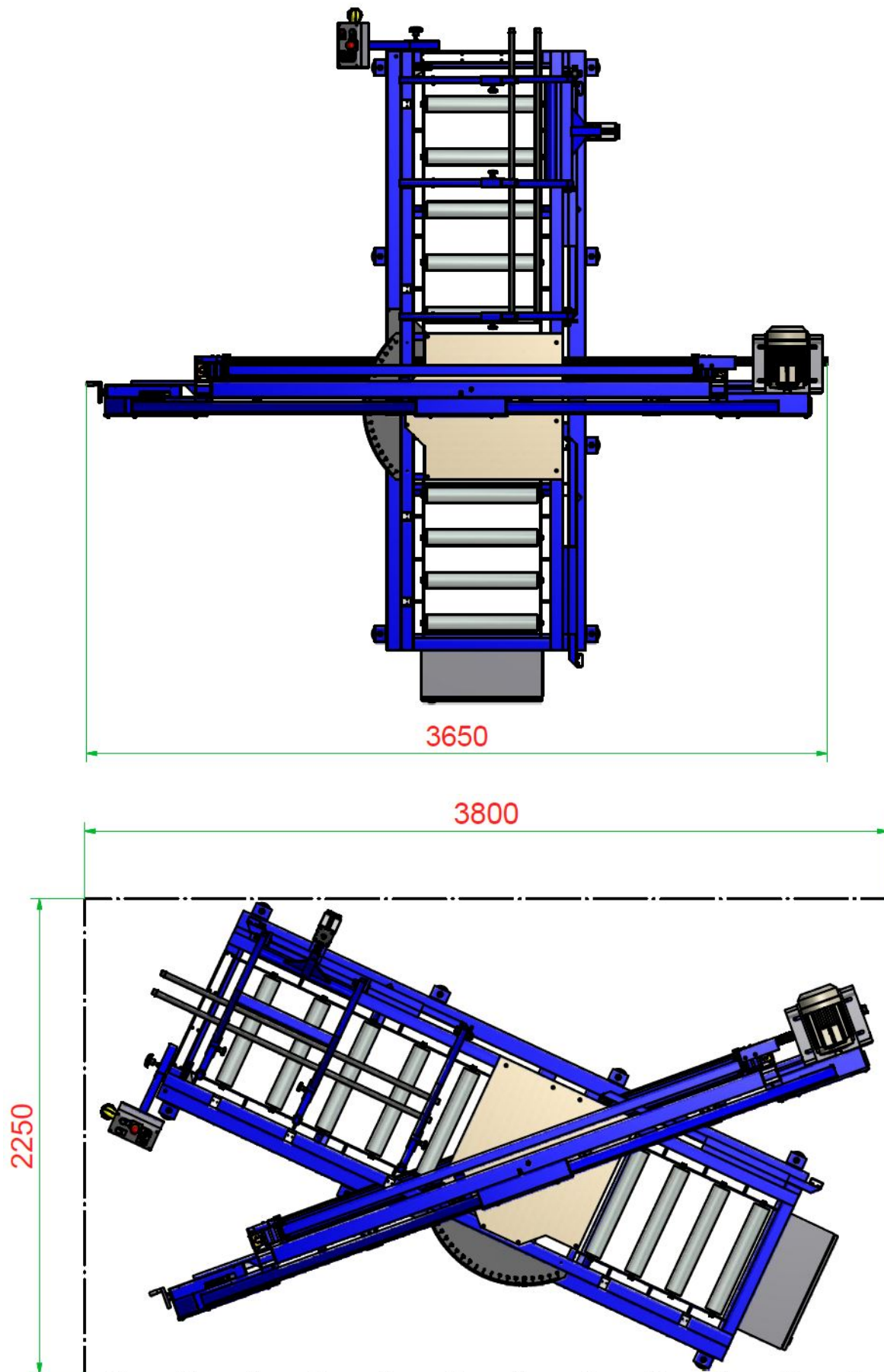

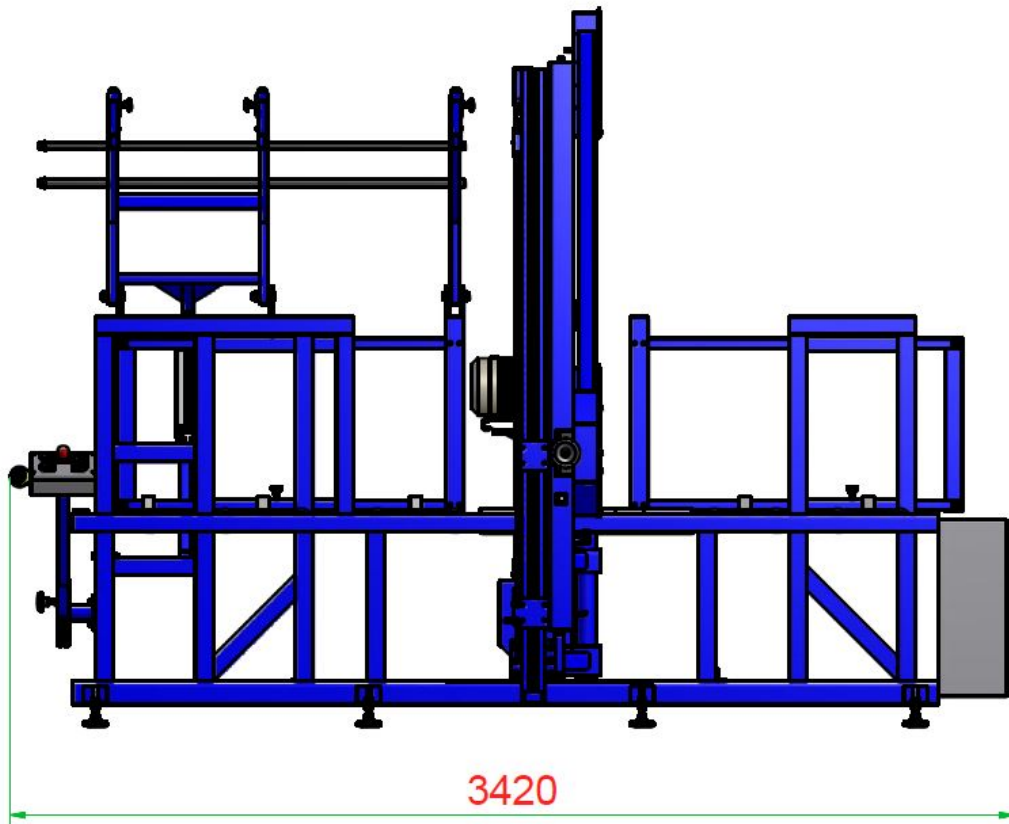

11.4 Circuit diagram

The following pages contain the electrical circuit diagrams for the BSM 631 / BSM 800 / BSM 1000.

11.5 Pneumatic diagram (optional)

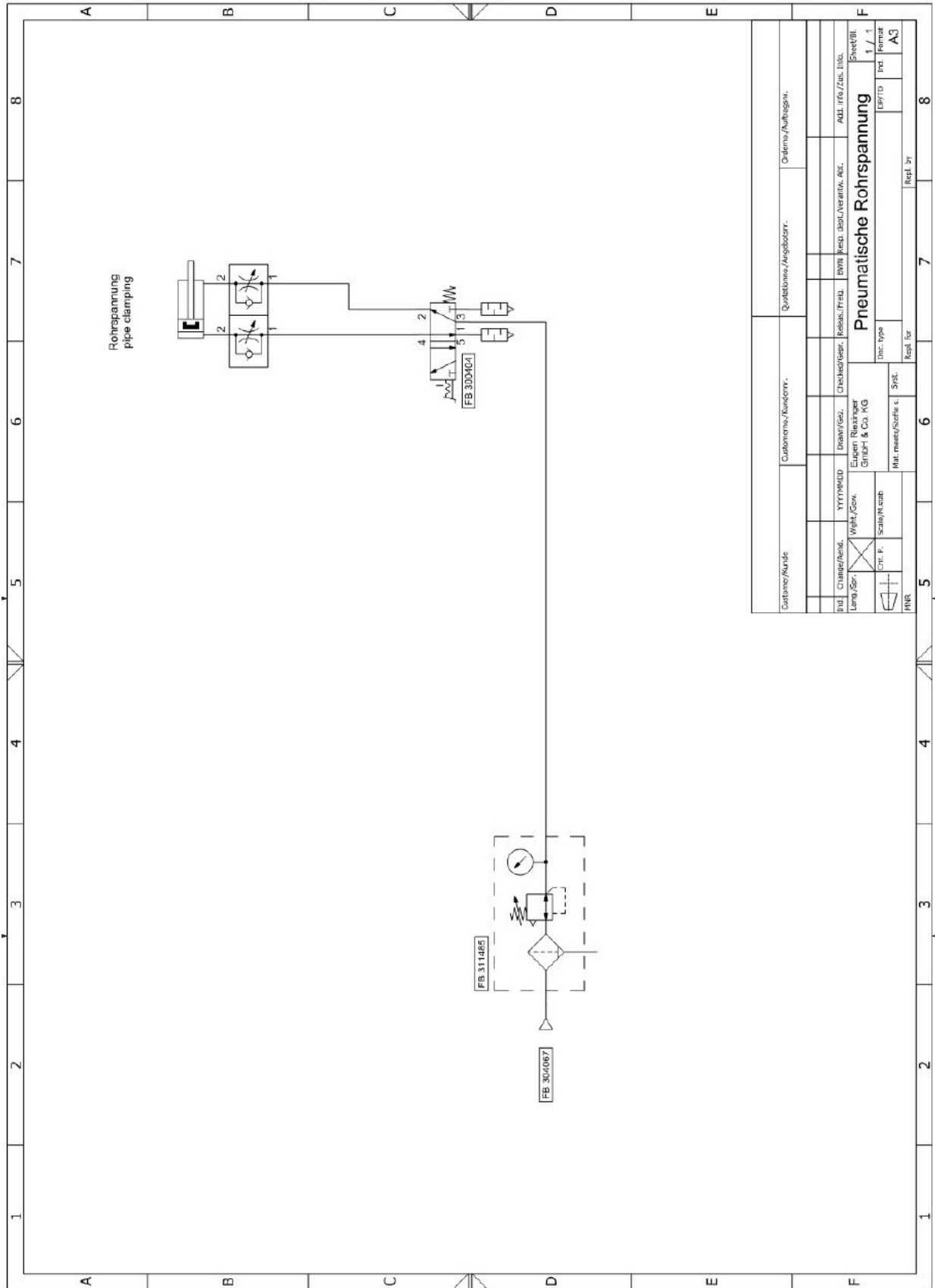

Customer/Kunde	Customer's/Клиент's	Quellenhinw./Angaberr.	Quellen/Aufgäberr.
Drawn/Gez. Checked/Gepr. Kebab./Прог. BWH/Kesp. des/Verantw. AGC. AUL/Trfo./Zus. lldc.	YYYMMDD Weight/Gew. Element/Rohrstoer GmbH & Co. KG	Drawn/Gez. Checked/Gepr. Kebab./Прог. BWH/Kesp. des/Verantw. AGC. AUL/Trfo./Zus. lldc.	Drawn/Gez. Checked/Gepr. Kebab./Прог. BWH/Kesp. des/Verantw. AGC. AUL/Trfo./Zus. lldc.
CHL P. Scale/Масш. PHR	Mat. munit./Сист.м.с. Syst.	Disc-type EPDM Repl. for	Sheet/Bl. 1 / 1 Format A3
Pneumatische Rohrspannung		Repl. by	

12. Other informations

The following pages contain the lubricating instructions for linear guideways and ballscrews of HIWIN Linartechnologie for the BSM 631 / BSM 800 / BSM 1000.

